



DANILO RAMAZZOTTI®
ITALIANHOUSEFLOOR

preview



*Non tutto ciò che è fatto a mano è bello a prescindere.
Altrimenti che differenza ci sarebbe tra un'opera d'arte e uno scarabocchio?*

*Non tutto ciò che un tempo era perfetto oggi lo è ancora.
Altrimenti nulla sarebbe cambiato.*

*Not everything that is handmade is beautiful regardless.
Otherwise, what difference would there be between an artwork and a doodle?*

*Not everything that once was perfect today it still is.
Our needs have changed.*

Danilo Ramazzotti

*CottoZero, il cotto fatto a mano come NON si faceva una volta.
CottoZero is THE handmade terracotta tile like it was never done before.*

It is 1956, when Danilo's mother opens a floor resale, they are mostly handcrafted cement tiles and marbles, and that's enough to make the admiration for those precise, measured and repetitive gestures grow in her child's eyes. at the basis of craftsmanship.

Over the years Danilo follows different paths that always bring him back to his true passion: design.

He has made deep friendships and collaborations with Achille Castiglioni, Richard Sapper and Gae Aulenti, which will lead him to reflect and find his own personal concept of design.

His design idea is strongly linked to the material and craftsmanship that are an inexhaustible source of study for him.

One day, called as a consultant for the floor restoration of a small church, he realizes that he is dealing with a very particular terracotta, a terracotta forgotten by history of which traces have been lost.

But Danilo loves challenges and thus begins his research, from clays to ancient production methods, to the creation of infinite samples, and when, finally, he learns all the secrets of this material, here he questions them again, until he finds the blends. and the techniques capable of creating a perfect cotto, a new one.

His goals are clear: to transform terracotta into a highly performing material suitable for the rhythms and needs of contemporary life.

This new terracotta must be resistant, compact, natural, breathable but at the same time more resistant to stains and easy to maintain, a terracotta made only of beauty and "zero" problems.

A cotto capable of starting a new tradition.
This is Danilo Ramazzotti's CottoZero.

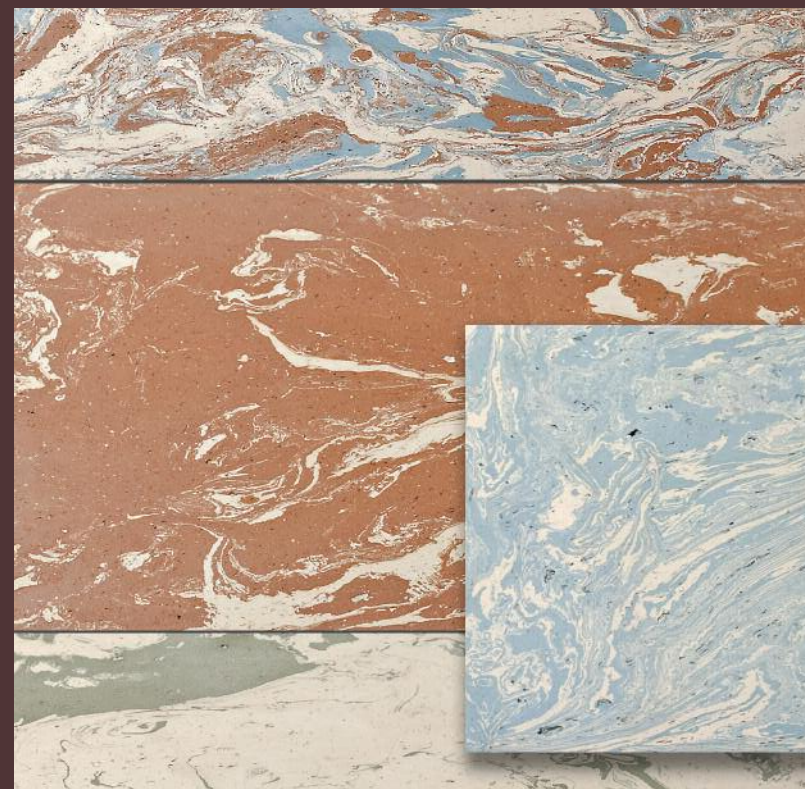



DANILO RAMAZZOTTI



E' il 1956, quando la mamma di Danilo apre una rivendita di pavimenti. Sono per lo più cementine e marmiglie realizzate artigianalmente e tanto basta per far crescere, nei suoi occhi di bambino, l'ammirazione per quei gesti precisi, misurati e ripetitivi che sono alla base dell'abilità artigiana.

Negli anni Danilo segue diverse strade che lo riportano sempre alla sua vera passione: il design.

Stringe profonde amicizie e collaborazioni con Achille Castiglioni, Richard Sapper e Gae Aulenti, che lo porteranno a riflettere ed a trovare un suo personale concetto di design.

La sua idea di design è fortemente legata alla materia e all'artigianalità che sono per lui una fonte inesauribile di studio. Un giorno, chiamato come consulente per il restauro pavimentale di una piccola chiesetta, si rende conto di avere a che fare con un cotto molto particolare, un cotto dimenticato dalla storia di cui si sono perse le tracce. Danilo adora le sfide e iniziano così le sue ricerche, dalle argille alle antiche metodologie di produzione, alla realizzazione di infiniti campioni, e quando, finalmente apprende tutti i segreti di questo materiale, ecco che li rimette nuovamente in discussione, fino a trovare le miscele e le tecniche in grado di creare un cotto perfetto, un cotto nuovo.

I suoi obiettivi sono ben chiari: trasformare il cotto in un materiale altamente performante e adatto ai ritmi e alle esigenze della vita contemporanea.

Questo nuovo cotto dovrà essere resistente, compatto, naturale, traspirante ma nel contempo più resistente alle macchie e di facile manutenzione, un cotto fatto solo di bellezza e "zero" problemi.

Un cotto in grado di iniziare una nuova tradizione.
Questo è il CottoZero di Danilo Ramazzotti.





**COTTO
ZERO**

ARGILLA PREZIOSA PRECIOUS CLAY

E' il 1850, quando Camillo Benso Conte di Cavour apre ufficialmente, per Regio decreto, le Cave piemontesi ai piedi del Monte Rosa.

Sono cave preziose, le cui argille, già utilizzate per la realizzazione di diversi manufatti dell'Impero Romano, pare siano state scelte anche da Leonardo Da Vinci, negli anni milanesi, per la preparazione dei suoi colori.

E come non citare Alessandro Antonelli, che per raggiungere i 121 metri della cupola di san Gaudenzio, ancora oggi una delle costruzioni in mattoni più alte del Mondo, si affida alla stessa terra per forgiarne i mattoni.

Scrive Sebastiano Vassalli: "Li ha scelti e toccati uno a uno per sentirne il suono"

Ma per quale motivo le argille dell'Alto Piemonte sono così performanti?

Questi giacimenti si trovano in realtà ai piedi un grandissimo ed antichissimo super vulcano, il più grande d' Europa, ed è proprio questa particolare condizione geologica ad averci lasciato un patrimonio così importante e così diversificato che conta, anche a distanza di pochi chilometri, giacimenti con caratteristiche tecniche e cromatismi molto diversi.

Il nostro lavoro parte da qui, dalla selezione di argille di altissima qualità e prosegue con una lavorazione per noi fondamentale: l'atomizzazione di queste terre per ottenere una polvere finissima.

Non utilizziamo mai una sola argilla, ma lavoriamo con delle vere e proprie ricette, testate e migliorate negli anni, composte da precise percentuali di argille diverse, scelte e dosate a seconda delle loro caratteristiche tecniche e cromatiche.

Nessun cotto tradizionale viene realizzato con questa tipologia di materia prima, ed è questo uno degli aspetti fondamentali che dona a CottoZero la sua compattezza e la sua resistenza e lo distingue da qualsiasi altro cotto in commercio.





It was 1850, when Camillo Benso, Count of Cavour officially opened, by Royal decree, the Piedmontese quarries at the foot of Monte Rosa.

They are precious quarries, whose clays, already used for the construction of various artifacts of the Roman Empire, seem to have also been chosen by Leonardo Da Vinci, in the Milanese years, for the preparation of his colors.

And how not to mention Alessandro Antonelli, who to reach the 121 meters of the dome of San Gaudenzio, still today the tallest brick building in the world, relies on the same earth to forge the bricks which, as Sebastiano Vassalli writes: "He chose them and touch each other one by one to hear the sound."

But why are the clays of Upper Piedmont so performing? These deposits are actually located at the foot of a very large and ancient super volcano, the largest in Europe, and it is precisely this particular geological condition that has left us such an important and diversified heritage that it counts, even at a distance of a few kilometers, deposits with very different technical characteristics and colors.

Our work starts from here, from the selection of the highest quality clays and continues with a process that is fundamental for us: the atomization of these clays to obtain a very fine powder.

We never use a single clay, but we work with real recipes, tested and improved over the years, made up of precise percentages of different clays, chosen and dosed according to their technical and chromatic characteristics.

No traditional terracotta is made with this type of raw material, and this is one of the fundamental aspects that gives CottoZero its compactness and resistance and distinguishes it from any other terracotta on the market.

COTTO
ZERO

NATURA CHE INSEGNA E ISPIRA NATURE THAT TEACHES AND INSPIRE

Come si può spiegare la differenza tra un cotto tradizionale e Cotto Zero?
Immaginatevi seduti nella vostra casa, in buona compagnia, di fronte ad un affascinante calice di vino.

Cosa fa di un vino un "grande vino"?

Il terroir, perché tutto parte sempre dalla Terra.

Una Terra intesa come Tutto.

Terra come magica connessione tra suolo, territorio, storia e componente umana, fatta di esperienza e tradizioni.

Il lavoro sapiente delle mani dell'uomo, perché è sempre l'esperienza che ci guida verso nuove intuizioni, che sono il germoglio dell'evoluzione.

Il tempo, perché quando si lavora con la Natura, la pazienza e il rispetto dei suoi cicli sono fondamentali.

La passione, perché è la passione che ti fa continuare, è la passione che ti fa migliorare, è la passione che ti porta ad immaginare il futuro e a darti l'energia per raggiungerlo.

Cosa fa di un cotto un CottoZero?

Le stesse identiche cose.

Un grande vino è sincero, fatto di fatica e di lavoro, un grande vino sa affascinarti, emozionarti, donarti gioia e scaldarti il cuore.

Il nostro cotto?

Le stesse identiche cose.

Una sola differenza: il nostro cotto è un piacere che dura per sempre.

Danilo Ramazzotti



How can you explain the difference between a traditional cotto and Cotto Zero? Imagine yourself sitting in your home, in good company, in front of a fascinating glass of wine.

What makes a wine a "great wine"?

Terroir, because everything always starts from the Earth.

An Earth understood as Everything.

Earth as the magical connection between soil, territory, history and human component, made of experience and traditions.

The skillful work of human hands, because it is always experience that guides us to new insights, which are the bud of evolution.

Time, because when working with Nature, patience and respect for its cycles are fundamental.

Passion, because it is passion that keeps you going, it is passion that makes you improve, it is passion that leads you to imagine the future and give you the energy to get there.

What makes a terracotta tile a CottoZero?

The exact same things.

A great Wine knows how to fascinate you, excite you, give you joy and warm your heart.

Our cotto? The exact same things.

Only one difference: our cotto is a pleasure that lasts forever.

Danilo Ramazzotti

COTTO
ZERO

F AVOLA AIRY TALES



La parola "favola" ci fa venire in mente qualcosa di inventato, ma anche qualcosa che di solito è troppo bello per essere vero.

Il nostro cotto è così, la sua semplicità racchiude il più magico dei racconti; la sua origine si perde nei tempi ma rinasce ogni giorno dagli stessi 4 elementi dalla poesia primordiale: terra, acqua, aria e fuoco

Il nostro cotto è come il pane: elemento fondamentale della quotidianità.

Il nostro cotto è calore, è casa, come il profumo del pane appena sfornato, legato al pane dagli stessi gesti, e, come il pane, offerto a noi dalla Natura stessa.

The word "fairy tale" makes us think of something made up, but also something that is usually too good to be true.

Our cotto is like that, its simplicity holds the most magical of tales; its origin is lost in time but reborn every day from the same 4 elements from primordial poetry: earth, water, air and fire.

Our cotto is like bread: a fundamental element of everyday life.

Our cotto is warmth, it is home, like the smell of freshly baked bread, linked to bread by the same gestures, and, like bread, offered to us by Nature itself.



*un dono della Natura
a gift from Nature*



COTTO
ZERO

FAVOLA
AIRY TALES

"I due odori più buoni e più santi son quelli
del pane caldo e della terra bagnata dalla pioggia."

*"The two best and holiest smells are those
of warm bread and of the rain-soaked earth."*
Ardengo Soffici





*one della semplicità
e perfection of simplicity*

COTTO
ZERO

F AVOLA AIRY TALES

Quando si lavora con la Natura, la pazienza e il rispetto dei suoi cicli sono fondamentali; immaginate i tempi di lievitazione o gli anni necessari ad un grande vino per il suo affinamento.

Per il nostro cotto è lo stesso.

Il nostro cotto è fatto completamente a mano, pezzo per pezzo, con meticolosa attenzione, e una volta stampato, vista la sua estrema compattezza, ha bisogno di un'essiccazione lenta e graduale.

La qualità va aspettata.

When working with Nature, patience and respect for his cycles are fundamental; imagine the leavening times or the years required for a great wine to refine.

It is the same for our cotto.

Our terracotta is made entirely by hand, piece by piece, with meticulous attention, and once printed, given its extreme compactness, it needs slow and gradual drying.

Quality must be await.



la paz





ienza del tempo
the patience of time



COTTO
ZERO

F

AVOLA
AIRY TALES



*la magia
the*





magic of transformation



**COTTO
ZERO**

N

ATURALE PER NATURA ATURAL FOR NATURE

Scegliere CottoZero significa scegliere un materiale che ci viene offerto dalla natura stessa.

CottoZero è un materiale completamente naturale, fatto di argilla, acqua, aria e fuoco, e vivere ogni giorno a stretto contatto con elementi naturali significa vivere meglio.

CottoZero non solo non rilascia sostanze nocive nell'ambiente, ma bensì è un materiale naturalmente traspirante, caratteristica che migliora la salubrità degli ambienti.

Nella produzione di CottoZero, viene posta particolare e costante attenzione all'impatto ambientale.

Le argille utilizzate sono di provenienza locale e l'acqua utilizzata viene atinta dal nostro pozzo aziendale, senza intaccare le risorse di acqua potabile. I nostri forni a basse emissioni vengono attivati solo a pieno carico per ottimizzare il dispendio energetico.

La sua altissima resistenza e la sua unicità permettono di realizzare pavimentazioni uniche dallo stile inimitabile e senza tempo, per questo un pavimento in CottoZero non solo ha un lunghissimo ciclo di vita, ma è un valore prezioso per te e per il tuo progetto, sia nell'immediato che nel tempo.

CottoZero è completamente naturale per questo può essere riciclato, recuperato e riutilizzato. Tutte queste caratteristiche fanno di CottoZero un materiale ecosostenibile.

Choosing CottoZero means choosing a material that is offered to us by nature itself.

CottoZero is a completely natural material made of clay, water, air and fire, and living every day in close contact with natural elements means living better.

CottoZero not only does not release harmful substances into the environment, but rather is a naturally breathable material, a characteristic that improves the healthiness of environments.

In the production of CottoZero, special and constant attention is paid to environmental impact.

The clays used are locally sourced and the water used is drawn from our farm well, without affecting our drinking water resources.

Our low-emission kilns are activated only at full load to optimize energy expenditure.

Its extremely high strength and uniqueness allow you to create unique flooring with an inimitable and timeless style, which is why a CottoZero floor not only has a very long life cycle, but is a valuable asset to you and your project, both immediately and over time.

CottoZero is completely natural so it can be recycled, recovered and reused.

All these characteristics make CottoZero an environmentally sustainable material.





**COTTO
ZERO**



INNOVARE LA TRADIZIONE
INNOVATE TRADITION

COTTO ZERO T

IME LINE

1981

Dopo attente ricerche e sperimentazioni viene prodotto il primo Cotto Danilo Ramazzotti realizzato esclusivamente con Argille del Monte Rosa. Questo cotto interamente piemontese è stato presentato alla presenza dell'allora Presidente della Regione Piemonte dott. Vittorio Beltrame e dell'Ordine degli Architetti di Novara.

After careful research and experimentation, the first Cotto Danilo Ramazzotti was produced, made exclusively with Monte Rosa clays. This entirely Piedmontese cooked product was presented in the presence of the then President of the Piedmont Region, Dr. Vittorio Beltrame and the Order of Architects of Novara.

1989

Danilo Ramazzotti vince a Tokyo il concorso Nikken "Casa Italiana"

Danilo Ramazzotti won the Nikken "Casa Italiana" competition in Tokyo.

1994

Le nuove collezioni sono presentate presso il Castello di Torre Canavese e la Fondazione Stelline di Milano.

Sempre nello stesso anno partecipa a Modena alla mostra internazionale di design "Oggetti dell'Abitare" insieme a Gae Aulenti, Achille Castiglioni, Bruno Munari, Richard Sapper, Cini Boeri, Alessandro Mendini, Attilio Marcolli, Toshiyuki Kita, Norbert Linke, Paolo Rizzato, Ugo La Pietra, Michael Graves, Roberto Sambonet, Philippe Starck, ed altri.

The new collections are presented at the Torre Canavese Castle and the Stelline Foundation in Milan.

Also in the same year, he participated in Modena in the international design exhibition "Oggetti dell'Abitare" together with Gae Aulenti, Achille Castiglioni, Bruno Munari, Richard Sapper, Cini Boeri, Alessandro Mendini, Attilio Marcolli, Toshiyuki Kita, Norbert Linke, Paolo Rizzato, Ugo La Pietra, Michael Graves, Roberto Sambonet, Philippe Starck...

1979

Danilo Ramazzotti è alla guida del Gruppo Ceramico Cantoia, azienda di famiglia dal 1956.

Danilo Ramazzotti is at the helm of the Gruppo Ceramico Cantoia, a family business since 1956.

1982/1988

I Cotti Variiegati di Danilo Ramazzotti, che propongono accanto a colorazioni classiche variegate a tre e quattro colori, rappresentano una grande svolta per questo materiale.

Vengono utilizzati per importanti progetti e pubblicati su famose riviste di settore tra cui: AD, Ville e Casali, Casa Oggi, Casabella, Modo, Bath Show Room, Tile italia...

Danilo Ramazzotti's Variegated terracotta tiles, which offer three and four color variegations alongside classic colours, represent a great turning point for this material.

They are used for important projects and published in famous sector magazines including: AD, Ville e Casali, Casa Oggi, Casabella, Modo, Bath Show Room, Tile Italia...

1990

La RAI, Radio Televisione Italiana, realizza all'interno di TG L'Una un servizio dedicato al Cotto Ramazzotti

RAI, Italian Radio Television, produces within TG L'Una a service dedicated to Cotto Ramazzotti

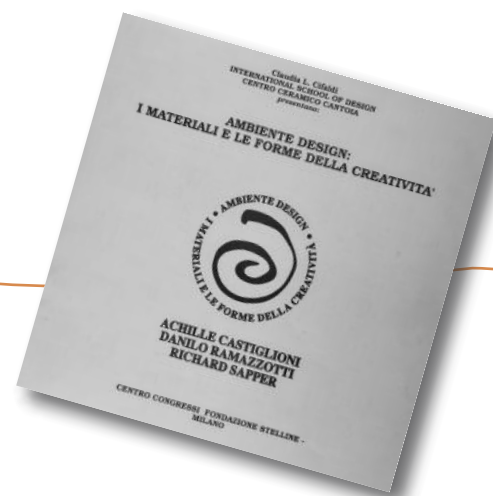

1995

Danilo Ramazzotti, Achille Castiglioni e Richard Sapper, sono i protagonisti della mostra "Ambiente design: i materiali e le forme della creatività" alla Fondazione Stelline di Milano a cura di Claudia Cifaldi.

Danilo Ramazzotti, Achille Castiglioni and Richard Sapper are the protagonists of the exhibition "Ambiente design: materials and forms of creativity" at the Stelline Foundation in Milan curated by Claudia Cifaldi.



1996

Danilo Ramazzotti passa sempre più tempo in fornace.

E' alla ricerca di un nuovo cotto che mantenga i risultati raggiunti a livello estetico ma che ne migliori le performances tecniche.

I tempi cambiano, anche il cotto deve cambiare.

Danilo Ramazzotti spends more and more time in the furnace.

He is looking for a new terracotta that maintains the results achieved on an aesthetic level but improves its technical performance.

Times change, even terracotta must change.



2007

Il Gruppo Ceramico Cantoia, sposta la produzione nella nuova unità produttiva di Vaprio d'Agogna.

Production is moved to the new production unit in Vaprio d'Agogna



DANILO RAMAZZOTTI
ITALIANHOUSEFLOOR

2019

Al Superstudio più, durante la Design Week Milanese, in collaborazione con Material Connexion e Marie Claire Maison viene presentato a "Materica" il nuovo Brand CottoZero.

At Superstudio Più, during the Milan Design Week, in collaboration with Material Connexion and Marie Claire Maison, the new CottoZero brand is presented at "Materica".

to be continued



1998

Danilo Ramazzotti riesce nell'intento.

Il suo cotto è un cotto "nuovo" che unisce le caratteristiche di un cotto fatto a mano tradizionale ma che è molto più compatto e resistente.

Si inizia un cammino di perfezionamento che porterà alla nascita di un cotto diverso: un cotto fatto a mano come non si è mai fatto prima

Danilo Ramazzotti succeeds in his aim.

His terracotta is a "new" terracotta that combines the characteristics of traditional handmade terracotta but is much more compact and resistant.

A path of improvement begins that will lead to the birth of a new terracotta: handmade terracotta like it has never been done before

2010

Danilo Ramazzotti e il figlio Glauco ottimizzano ulteriormente le prestazioni tecniche del cotto fino ad ottenere un prodotto dalle caratteristiche incredibili: nasce il primo CottoZero.

Danilo Ramazzotti together with his son Glauco further optimized the technical performance of terracotta until obtaining a product with incredible qualities: the first CottoZero was born.

DANILO RAMAZZOTTI®
ITALIANHOUSEFLOOR

2011

L'interesse di Danilo Ramazzotti non è solo rivolto al cotto.

La pietra naturale, la maiolica e la ceramica fatta a mano sono gli altri ambiti di produzione su cui l'azienda lavora ormai da decenni. Le produzioni nascono con l'intento di creare materiali su misura per poter progettare in piena libertà, senza doversi uniformare ai canoni della produzione industriale.

La richiesta di queste particolari materiali aumenta a tal punto che viene creato il brand "Danilo Ramazzotti Italianhousefloor" Inizia così la distribuzione dei prodotti a marchio Ramazzotti.

Danilo Ramazzotti's interest is not only in terracotta.

Natural stone, majolica and handmade ceramic are the other areas of production on which the company has been working for decades.

The productions are born with the intention of creating tailor-made materials to be able to design in complete freedom, without having to conform to the canons of industrial production.

The demand for these particular materials increases to such an extent that the "Danilo Ramazzotti Italianhousefloor" brand is created

Thus began the distribution of Ramazzotti brand products.

**COTTO
ZERO**

INNOVARE LA TRADIZIONE **INNOVATE TRADITION**

PRODUZIONE **COTTO TRADIZIONALE ITALIANO**

ARGILLE:

argilla proveniente da una cava in prossimità della fornace.
L'argilla viene lavorata con aggiunta di acqua fino ad ottenere una "pasta molle" della consistenza simile ad un dentifricio.

LAVORAZIONE:

l'impasto viene inserito in cornici di legno e ripassato sulla parte superiore con un regolo di legno per livellare la superficie.
Le piastrelle appena formate vengono disposte accostate su un pavimento in cemento fino ad asciugatura.

COTTURA:

i cotti una volta asciutti vengono impilati per la cottura in forno.
Per i prodotti meno pregiati la cottura avviene a 600°/800°.

CottoZero DANILO RAMAZZOTTI

ARGILLE:

Cotto Zero è ottenuto da argille provenienti da diverse cave situate ai piedi del Monte Rosa. Le argille utilizzate, vengono sottoposte al processo di atomizzazione che le trasforma in un talco finissimo.

Le diverse argille vengono miscelate a secco, secondo le loro caratteristiche tecniche e sulla base di precise ricette, per ottenere un impasto performante, oltre alle diverse colorazioni in gamma. All'impasto viene aggiunta pochissima acqua, fino ad ottenere un impasto compatto e consistente. ("pasta dura")

LAVORAZIONE:

l'impasto viene lavorato a mano secondo due tecniche diverse, a piccoli "panetti" o a "pane" intero, dove l'impasto viene preso e battuto più volte su un piano per essere compattato, fino ad ottenere un parallelepipedo.
Gli stampi in legno vengono spolverati di sabbia, viene appoggiato il pane e si procede con una torchiatura del pezzo. Questo processo compatta ulteriormente l'argilla.
Estratto dal torchio il pezzo viene livellato con l'utilizzo di un filo per togliere le abbondanze. Lo stampo viene poi capovolto ed il pezzo ottenuto viene disposto su griglie metalliche.

I pezzi vengono posti in essiccatoio a umidità e temperatura controllata.
La grande compattezza dell'argilla necessita di lunghi tempi di asciugatura.

COTTURA:

i cotti, una volta asciutti, vengono posizionati per la cottura in forno a muffola.
In forno vengono utilizzate particolari curve di cottura a una temperatura che supera abbondantemente i 1000°.



PRODUCTION

TRADITIONAL ITALIAN TERRACOTTA

CLAY:

clay from a quarry near the furnace.
The clay is worked with the addition of water to obtain a "soft paste" with a consistency similar to a toothpaste.

PROCESSING:

the dough is placed in wooden frames and passed over the top with a wooden ruler to level the surface.
The newly formed tiles are placed side by side on a concrete floor until dry.

COOKING:

Once dry, the terracotta tiles are stacked for baking.
For less valuable products, cooking takes place at 600 °/800 °.

CottoZero **DANILO RAMAZZOTTI**

CLAY:

Cotto Zero is obtained from clays from various quarries located at the foot of Monte Rosa. The clays used are subjected to the atomization process which transforms them into a very fine talc.

The different clays are dry mixed, based on their technical characteristics and on the basis of precise recipes, to obtain a performing mixture, and the different colors in the range. Very little water is added to the mixture, until a compound is obtained a compact and consistent dough. ("Hard pasta")

PROCESSING:

the dough is worked by hand according to two different techniques, in "pani" or "panini", where the dough is picked up and beaten several times on a surface to compact it. The mold is dusted with sand, the bread is laid down and the piece is pressed. This process further compacts the clay. The piece is leveled by cutting with the use of a wire to remove excess. The mold is then overturned and the piece obtained is placed on metal grids. The pieces are placed in a dryer with controlled humidity and temperature. The compactness of the clay requires long drying times.

COOKING:

Special cooking curves are used in the oven at a temperature that well exceeds 1000°.

**COTTO
ZERO**

INNOVARE LA TRADIZIONE
INNOVATE TRADITION

CARATTERISTICHE **COTTO TRADIZIONALE ITALIANO**

COMPATTEZZA:

Il cotto tradizionale si presenta come un materiale poroso che porta al suo interno delle piccole cavità. Questo aspetto è riscontrabile anche attraverso l'udito: colpendolo leggermente se ne ricaverà un suono sordo.

ASSORBENZA:

Il cotto è un materiale assorbente, la presenza delle numerose cavità aumenta questo aspetto.

MANUTENZIONE:

Dopo la posa il cotto viene protetto con prodotti pellicolanti, questo ne annulla la naturale traspirabilità. Ogni 2/3 anni, va prevista una manutenzione straordinaria: il cotto va decerato, lavato con un detergente apposito, ritrattato e cerato nuovamente. L'intervento deve essere svolto da personale qualificato.

LEVIGATURA IN OPERA:

E' possibile effettuare la levigatura in opera.

CottoZero DANILO RAMAZZOTTI

COMPATTEZZA:

CottoZero è molto più compatto di un cotto tradizionale. L'utilizzo di argille finissime, l'impasto a pasta dura e la successiva torchiatura riducono notevolmente la presenza e la dimensione delle cavità. Colpendolo leggermente se ne ricaverà un suono diverso, quasi cristallino. CottoZero ha una resistenza meccanica 3 volte superiore ad un cotto tradizionale.

ASSORBENZA:

CottoZero assorbe il 70% in meno di un cotto tradizionale. La ridotta assorbenza rende CottoZero particolarmente resistente alle macchie.

MANUTENZIONE:

Dopo la posa il nostro cotto viene trattato con prodotti impregnanti in grado di proteggere la superficie mantenendone la normale traspirabilità. La traspirabilità dei materiali naturali è una importante caratteristica di benessere. Dopo gli interventi previsti a fine posa si può procedere alla normale pulizia quotidiana e ad un lavaggio con un detergente neutro. All'occorrenza, circa una volta l'anno, è possibile diluire un tappo di cera idrosolubile nell'acqua e procedere ad un normale lavaggio.

LEVIGATURA IN OPERA:

E' possibile effettuare la levigatura in opera.

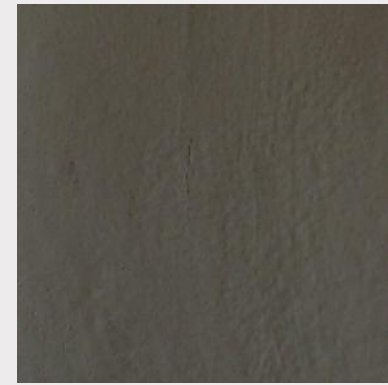

FEATURES

TRADITIONAL ITALIAN TERRACOTTA

COMPACTNESS:

Traditional terracotta looks like a porous material that carries small cavities inside.

This aspect can also be found through hearing: hitting it lightly will result in a dull sound.

ABSORBANCE:

Terracotta is an absorbent material, the presence of numerous cavities increases this aspect.

MAINTENANCE:

after laying, the terracotta is protected with filming products, this cancels its natural transpiration. Every 2/3 years extraordinary maintenance must be carried out: the terracotta must be dewaxed, washed with a suitable detergent, reprocessed and waxed again. The intervention must be carried out by qualified personnel.

POLISHING ON SITE:

On-site polishing is possible.

CottoZero DANILO RAMAZZOTTI

COMPACTNESS:

Cotto Zero is much more compact than a traditional cotto.

The use of very fine clays, the hard dough and the subsequent pressing greatly reduce the presence and size of the cavities.

Hitting it lightly will produce a different, almost crystalline sound.

Cotto Zero has a mechanical resistance 3 times higher than a traditional cotto.

ABSORBENCE:

Cotto Zero absorbs 70% less than traditional cooked.

The reduced absorbency makes Cotto Zero particularly resistant to stains.

MAINTENANCE:

After installation, our terracotta is treated with impregnating products capable of protecting the surface while maintaining normal breathability.

The breathability of natural materials is an important well-being feature.

Normal daily cleaning and washing with a neutral detergent.

If necessary, about once a year, it is possible to dilute a cap of water-soluble wax in water and proceed with a normal washing.

POLISHING ON SITE:

On-site polishing it is possible.



**COTTO
ZERO**

**INDICE
INDEX**

PG 34 - CottoZero COTTO STORICO PIEMONTESE

PG 38 - CottoZero ITALIA / ITALIA ANTICA

PG 46 - CottoZero ARGILLE NOBILI

PG 50 - CottoZero TERRE PURE

PG 56 - CottoZero VENTILATO

PG 64 - CottoZero PIETRAMÈ

PG 70 - CottoZero VARIEGATO

PG 84 - CottoZero SCIRUSS

PG 92 - CottoZero DESIGN

PG 102 - DETTAGLI TECNICI / DETAILS

PG 106 - PEZZI SPECIALI/SPECIAL PIECES
BATTISCOPA E SCALE /BASEBOARD AND STAIRS

PG 112 - COLORI / COLORS

**COTTO
ZERO**



OTTO STORICO PIEMONTESE

Entrando in chiese e antichi palazzi della nostro territorio capita spesso di incontrare meravigliosi pavimenti in cotto.

Sono cotti molto particolari, di un colore rosato carico e intessuti di piccoli frammenti che vanno dall'avorio al color terracotta.

Questi cotti raccontano la quotidianità di lavorazioni artigianali eseguite mescolando le principali argille locali che presentavano al loro interno tutto ciò che la natura offriva: impurità, frammenti di argille diverse, piccoli ciottoli... così, quello che un tempo era semplicemente il frutto di ciò che il suolo offriva, col passare dei secoli si è trasformato in un materiale ben preciso, come parte di un codice, in grado di fornirci il periodo storico di riferimento della costruzione stessa.

Dopo secoli, abbiamo deciso di ridare voce al nostro cotto storico.

Questo cotto nasce per essere esteticamente affine al cotto dei nostri avi, ma carico di tutti i plus di CottoZero.

Un cotto così prezioso e dal colore così particolare non poteva che ispirarsi ad una donna e ad una storia d'amore; così, nelle nostre fornaci "rinasce" il cotto storico piemontese dedicato alla "Bella Rusin".

Upon entering churches and ancient palaces in our area, it often happens that one encounters wonderful terracotta floors.

They are very special terracottas, a deep pinkish color and interwoven with small fragments ranging from ivory to terracotta in color.

These cottos tell the story of everyday craftsmanship carried out by mixing the main local clays, which presented within them everything that nature offered: impurities, fragments of different clays, small pebbles... thus, what was once simply the fruit of what the soil offered, over the centuries has been transformed into a very precise material, as part of a code, able to provide us with the historical period of reference of the construction itself.

After centuries, we decided to give our historic terracotta a voice again.

This cotto was born to be aesthetically akin to the cotto of our ancestors, but loaded with all the pluses of CottoZero.

A cotto so precious and with such a special color could only be inspired by a woman and a love story; thus, in our kilns "reborn" historical Piedmontese cotto dedicated to "Bella Rusin."



**COTTO
ZERO**

C

OTTO STORICO PIEMONTESE

SIZES COLORS:

QUADRATO / SQUARE

10x10x2	cm - $3'' \frac{15}{16} \times 3'' \frac{15}{16} \times \frac{25}{32}''$
20x20x2	cm - $7'' \frac{7}{8} \times 7'' \frac{7}{8} \times \frac{25}{32}''$
25x25x2	cm - $9'' \frac{27}{32} \times 9'' \frac{27}{32} \times \frac{25}{32}''$
30x30x2	cm - $11'' \frac{13}{16} \times 11'' \frac{13}{16} \times \frac{25}{32}''$
40x40x2,5	cm - $15'' \frac{3}{4} \times 15'' \frac{3}{4} \times \frac{63}{64}''$

RETTANGOLO / RECTANGLE

8x33x2	cm - $3'' \frac{5}{32} \times 12'' \frac{63}{64} \times \frac{25}{32}''$
10x20x2	cm - $3'' \frac{15}{16} \times 7'' \frac{7}{8} \times \frac{25}{32}''$
10x40x2	cm - $3'' \frac{15}{16} \times 15'' \frac{3}{4} \times \frac{25}{32}''$
12x48x2	cm - $4'' \frac{23}{32} \times 18'' \frac{57}{64} \times \frac{25}{32}''$
14x60x2,5	cm - $5'' \frac{33}{64} \times 23'' \frac{5}{8} \times \frac{63}{64}''$
15x30x2	cm - $5'' \frac{29}{32} \times 11'' \frac{13}{16} \times \frac{25}{32}''$
20x40x2	cm - $7'' \frac{7}{8} \times 15'' \frac{3}{4} \times \frac{25}{32}''$
20x60x3	cm - $7'' \frac{7}{8} \times 23'' \frac{5}{8} \times 1'' \frac{3}{16}$
20x80x3	cm - $7'' \frac{7}{8} \times 31'' \frac{1}{2} \times 1'' \frac{3}{16}$
30x60x2	cm - $11'' \frac{13}{16} \times 23'' \frac{5}{8} \times \frac{25}{32}''$

ROMBO / RHOMBUS

16,5x29x2	cm - $6'' \frac{1}{2} \times 11'' \frac{27}{64} \times \frac{25}{32}''$
-----------	---

ESAGONO / EXAGON

Lato 11 cm, sp. 2 cm	- Side $4'' \frac{21}{64}$, THK $\frac{25}{32}''$
Lato 16 cm, sp. 2 cm	- Side $6'' \frac{19}{64}$, THK $\frac{25}{32}''$

FINITURE / FINISHING

levigato a mano / smoothed by hand

PEZZI SPECIALI / SPECIAL PIECES

pezzi per scale e battiscopa vedi pag. 108
pieces for stairs and baseboard on page 108

CUSTOM MADE

formati speciali e lati rettificati a richiesta
special formats and ground sides on request



BELLA RUSIN

NOTE:

cotto fatto a mano - colori e caratteristiche estetiche sono da considerarsi indicativi, misure nominali
handmade terracotta - colors and aesthetic characteristics are to be considered indicative, nominal measurements



**COTTO
ZERO**

TALIA / ITALIA ANTICA

CottoZero interpreta la tradizione con questo cotto dedicato all'Italia. Questo cotto viene realizzato con preziose argille provenienti da cave aperte nel 1850 da Camillo Benso Conte di Cavour, lo stesso Cavour che per primo ricoprì la carica di Primo Ministro del Regno d'Italia.

CottoZero Italia è un cotto dalla superficie naturale, e i due colori scelti sono quelli tipici del cotto italiano. La sua lavorazione artigianale lo rende perfetto per tutte le tipologie di ripristino di ambienti storici o per nuove interpretazioni progettuali in cui si voglia dare particolare carattere alla pavimentazione.

La versione CottoZero Italia Antica si veste di una particolare finitura strutturata, irregolare ammorbidita dal tempo.

CottoZero interprets tradition with this cotto dedicated to Italy. This cotto is made with precious clays from quarries opened in 1850 by Camillo Benso Count of Cavour, the same Cavour who first held the office of Prime Minister of the Kingdom of Italy.

CottoZero Italia is a cotto with a natural surface, and the two colors chosen are those typical of Italian cotto. Its craftsmanship makes it perfect for all types of restoration of historic environments or for new design interpretations where you want to give special character to the flooring.

The CottoZero Italia Antica version is dressed with a special irregular finish softened by time.

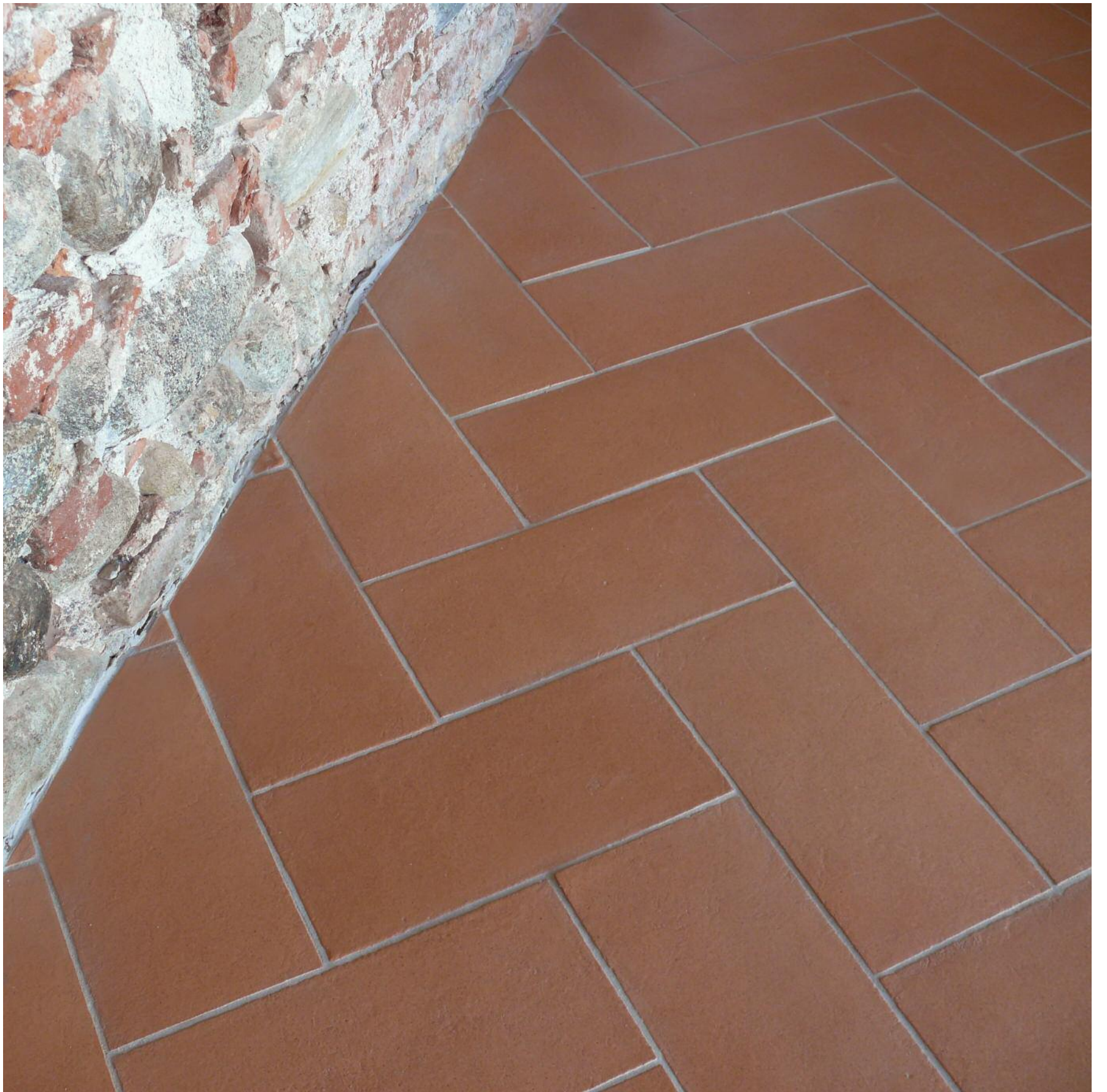

COTTO ZERO

ITALIA / ITALIA ANTICA

SIZES COLORS:

QUADRATO / SQUARE

10x10x2	cm - 3" ¹⁵ / ₁₆ x 3" ¹⁵ / ₁₆ x ²⁵ / ₃₂ "
20x20x2	cm - 7" ⁷ / ₈ x 7" ⁷ / ₈ x ²⁵ / ₃₂ "
25x25x2	cm - 9" ²⁷ / ₃₂ x 9" ²⁷ / ₃₂ x ²⁵ / ₃₂ "
30x30x2	cm - 11" ¹³ / ₁₆ x 11" ¹³ / ₁₆ x ²⁵ / ₃₂ "
40x40x2,5	cm - 15" ³ / ₄ x 15" ³ / ₄ x ⁶³ / ₆₄ "

RETTANGOLO / RECTANGLE

8x33x2	cm - 3" ⁵ / ₃₂ x 12" ⁶³ / ₆₄ x ²⁵ / ₃₂ "
10x20x2	cm - 3" ¹⁵ / ₁₆ x 7" ⁷ / ₈ x ²⁵ / ₃₂ "
10x40x2	cm - 3" ¹⁵ / ₁₆ x 15" ³ / ₄ x ²⁵ / ₃₂ "
12x48x2	cm - 4" ²³ / ₃₂ x 18" ⁵⁷ / ₆₄ x ²⁵ / ₃₂ "
14x60x2,5	cm - 5" ³³ / ₆₄ x 23" ⁵ / ₈ x ⁶³ / ₆₄ "
15x30x2	cm - 5" ²⁹ / ₃₂ x 11" ¹³ / ₁₆ x ²⁵ / ₃₂ "
20x40x2	cm - 7" ⁷ / ₈ x 15" ³ / ₄ x ²⁵ / ₃₂ "
20x60x3	cm - 7" ⁷ / ₈ x 23" ⁵ / ₈ x 1" ³ / ₁₆
20x80x3	cm - 7" ⁷ / ₈ x 31" ¹ / ₂ x 1" ³ / ₁₆
30x60x2	cm - 11" ¹³ / ₁₆ x 23" ⁵ / ₈ x ²⁵ / ₃₂ "

ROMBO / RHOMBUS

16,5x29x2	cm - 6" ¹ / ₂ x 11" ²⁷ / ₆₄ x ²⁵ / ₃₂ "
-----------	---

ESAGONO / EXAGON

Lato 11 cm, sp. 2 cm	- Side 4" ²¹ / ₆₄ , THK ²⁵ / ₃₂ "
Lato 16 cm, sp. 2 cm	- Side 6" ¹⁹ / ₆₄ , THK ²⁵ / ₃₂ "

FINITURE / FINISHING

ITALIA: naturale / natural
ITALIA ANTICA: anticata / antique

PEZZI SPECIALI / SPECIAL PIECES

pezzi per scale e battiscopa vedi pag. 108
pieces for stairs and baseboard on page 108

CUSTOM MADE

formati speciali e lati rettificati a richiesta
special formats and ground sides on request



ITALIA ROSSO



ITALIA ROSATO



ITALIA ANTICA ROSSO



ITALIA ANTICA ROSATO

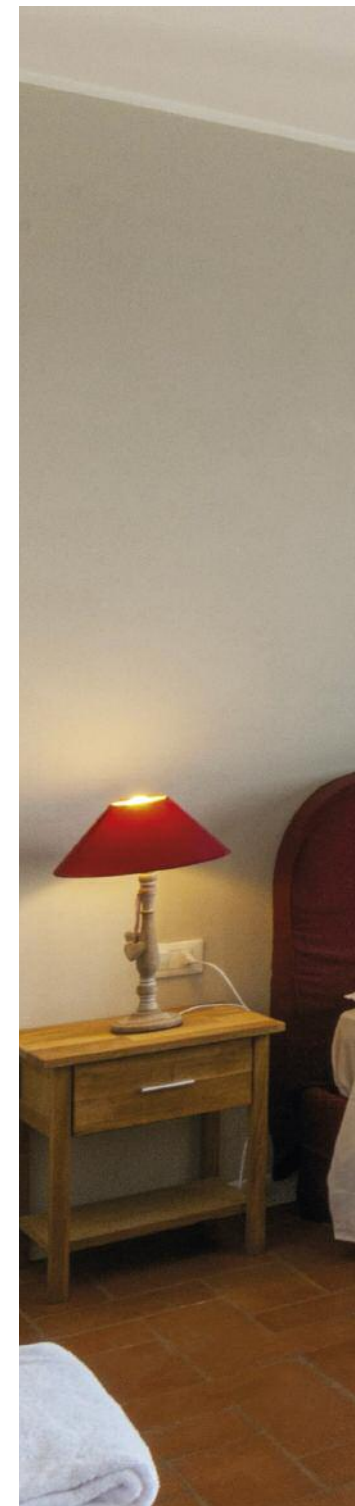

NOTE:

cotto fatto a mano - colori e caratteristiche estetiche sono da considerarsi indicativi, misure nominali
handmade terracotta - colors and aesthetic characteristics are to be considered indicative, nominal measurements



COTTO ZERO A RGILLE NOBILI

Il Cotto Zero Argille Nobili nasce dall'osservazione delle nostre terre del novarese.

Terre compatte che sotto al sole si asciugano e si trasformano in superfici solide e strutturate, solcate da linee irregolari, da sottili crepe, costellate di sfumature polverose e dalle tracce dell'acqua ormai evaporata.

La stessa poesia si esprime nella matericità di questi cotti, realizzati e levigati completamente a mano per conservare le caratteristiche di una texture unica.

Una matericità importante che sa essere rustica e contemporanea, calda ed essenziale.

Cotto Zero Argille Nobili was born from observation of our Novara lands.

Compact soils that under the sun dry and turn into solid and textured surfaces, furrowed by irregular lines, subtle cracks, dotted with dusty shades and the traces of water that has now evaporated.

The same poetry is expressed in the materiality of these terracotta tiles, made and polished completely by hand to preserve the characteristics of a unique texture.

An important materiality that knows how to be both rustic and contemporary, warm and essential.







COTTO ZERO

A

RGILLE NOBILI

SIZES COLORS:

QUADRATO / SQUARE

10x10x2	cm - 3" ¹⁵ / ₁₆ x 3" ¹⁵ / ₁₆ x ²⁵ / ₃₂ "
20x20x2	cm - 7" ⁷ / ₈ x 7" ⁷ / ₈ x ²⁵ / ₃₂ "
25x25x2	cm - 9" ²⁷ / ₃₂ x 9" ²⁷ / ₃₂ x ²⁵ / ₃₂ "
30x30x2	cm - 11" ¹³ / ₁₆ x 11" ¹³ / ₁₆ x ²⁵ / ₃₂ "
40x40x2,5	cm - 15" ³ / ₄ x 15" ³ / ₄ x ⁶³ / ₆₄ "

RETTANGOLO / RECTANGLE

8x33x2	cm - 3" ⁵ / ₃₂ x 12" ⁶³ / ₆₄ x ²⁵ / ₃₂ "
10x20x2	cm - 3" ¹⁵ / ₁₆ x 7" ⁷ / ₈ x ²⁵ / ₃₂ "
10x40x2	cm - 3" ¹⁵ / ₁₆ x 15" ³ / ₄ x ²⁵ / ₃₂ "
12x48x2	cm - 4" ²³ / ₃₂ x 18" ⁵⁷ / ₆₄ x ²⁵ / ₃₂ "
14x60x2,5	cm - 5" ³³ / ₆₄ x 23" ⁵ / ₈ x ⁶³ / ₆₄ "
15x30x2	cm - 5" ²⁹ / ₃₂ x 11" ¹³ / ₁₆ x ²⁵ / ₃₂ "
20x40x2	cm - 7" ⁷ / ₈ x 15" ³ / ₄ x ²⁵ / ₃₂ "
20x60x3	cm - 7" ⁷ / ₈ x 23" ⁵ / ₈ x 1" ³ / ₁₆
20x80x3	cm - 7" ⁷ / ₈ x 31" ¹ / ₂ x 1" ³ / ₁₆
30x60x2	cm - 11" ¹³ / ₁₆ x 23" ⁵ / ₈ x ²⁵ / ₃₂ "

ROMBO / RHOMBUS

16,5x29x2	cm - 6" ¹ / ₂ x 11" ²⁷ / ₆₄ x ²⁵ / ₃₂ "
-----------	---

ESAGONO / EXAGON

Lato 11 cm, sp. 2 cm	- Side 4" ²¹ / ₆₄ , THK ²⁵ / ₃₂ "
Lato 16 cm, sp. 2 cm	- Side 6" ¹⁹ / ₆₄ , THK ²⁵ / ₃₂ "

FINITURE / FINISHING

carteggiato a mano/sanded by hand

PEZZI SPECIALI / SPECIAL PIECES

pezzi per scale e battiscopa vedi pag. 108
pieces for stairs and baseboard on page 108

CUSTOM MADE

formati speciali e lati rettificati a richiesta
special formats and ground sides on request



VERBANIA

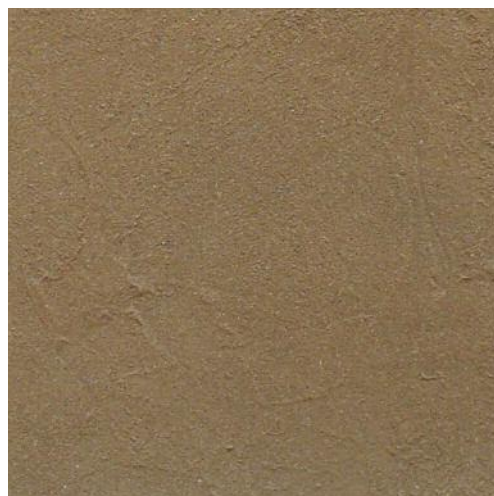

ORTA

NOTE:

cotto fatto a mano - colori e caratteristiche estetiche sono da considerarsi indicative, misure nominali
handmade terracotta - colors and aesthetic characteristics are to be considered indicative, nominal measurements



COTTO ZERO

A

RGILLE NOBILI

SIZES COLORS:

QUADRATO / SQUARE

10x10x2	cm - 3" ¹⁵ / ₁₆ x 3" ¹⁵ / ₁₆ x ²⁵ / ₃₂ "
20x20x2	cm - 7" ⁷ / ₈ x 7" ⁷ / ₈ x ²⁵ / ₃₂ "
25x25x2	cm - 9" ²⁷ / ₃₂ x 9" ²⁷ / ₃₂ x ²⁵ / ₃₂ "
30x30x2	cm - 11" ¹³ / ₁₆ x 11" ¹³ / ₁₆ x ²⁵ / ₃₂ "
40x40x2,5	cm - 15" ³ / ₄ x 15" ³ / ₄ x ⁶³ / ₆₄ "

RETTANGOLO / RECTANGLE

8x33x2	cm - 3" ⁵ / ₃₂ x 12" ⁶³ / ₆₄ x ²⁵ / ₃₂ "
10x20x2	cm - 3" ¹⁵ / ₁₆ x 7" ⁷ / ₈ x ²⁵ / ₃₂ "
10x40x2	cm - 3" ¹⁵ / ₁₆ x 15" ³ / ₄ x ²⁵ / ₃₂ "
12x48x2	cm - 4" ²³ / ₃₂ x 18" ⁵⁷ / ₆₄ x ²⁵ / ₃₂ "
14x60x2,5	cm - 5" ³³ / ₆₄ x 23" ⁵ / ₈ x ⁶³ / ₆₄ "
15x30x2	cm - 5" ²⁹ / ₃₂ x 11" ¹³ / ₁₆ x ²⁵ / ₃₂ "
20x40x2	cm - 7" ⁷ / ₈ x 15" ³ / ₄ x ²⁵ / ₃₂ "
20x60x3	cm - 7" ⁷ / ₈ x 23" ⁵ / ₈ x 1" ³ / ₁₆
20x80x3	cm - 7" ⁷ / ₈ x 31" ¹ / ₂ x 1" ³ / ₁₆
30x60x2	cm - 11" ¹³ / ₁₆ x 23" ⁵ / ₈ x ²⁵ / ₃₂ "

ROMBO / RHOMBUS

16,5x29x2	cm - 6" ¹ / ₂ x 11" ²⁷ / ₆₄ x ²⁵ / ₃₂ "
-----------	---

ESAGONO / EXAGON

Lato 11 cm, sp. 2 cm	- Side 4" ²¹ / ₆₄ , THK ²⁵ / ₃₂ "
Lato 16 cm, sp. 2 cm	- Side 6" ¹⁹ / ₆₄ , THK ²⁵ / ₃₂ "

FINITURE / FINISHING

carteggiato a mano / sanded by hand

PEZZI SPECIALI / SPECIAL PIECES

pezzi per scale e battiscopa vedi pag. 108
pieces for stairs and baseboard on page 108

CUSTOM MADE

formati speciali e lati rettificati a richiesta
special formats and ground sides on request



STRESA



BAVENO



ARONA



CANNOBIO

NOTE:

cotto fatto a mano - colori e caratteristiche estetiche sono da considerarsi indicativi, misure nominali
handmade terracotta - colors and aesthetic characteristics are to be considered indicative, nominal measurements



COTTO ZERO T ERRE PURE

Cotto Zero Terre Pure racchiude la bellezza di una matericità dolce e vellutata.

La particolare lavorazione e la successiva spazzolatura conferiscono a questo cotto un morbido e raffinato movimento superficiale che si traduce in una cifra unica e singolare, dove è la luce radente ad evidenziare la differenza di ogni singolo pezzo.

Le argille esprimono appieno la loro compattezza ed i loro cromatismi, regalando superfici che raccontano la bellezza sobria ed irripetibile della natura.

Cotto Zero Terre Pure encapsulates the beauty of a soft and velvety materiality.

The special processing and subsequent brushing give this cotto a soft and refined surface movement that results in a unique and singular figure, where it is the grazing light that highlights the difference of each piece.

The clays fully express their compactness and chromatics, giving surfaces that tell of the understated and unrepeatabe beauty of nature.



COTTO ZERO

T

ERRE PURE

SIZES COLORS:

QUADRATO / SQUARE

10x10x2	cm - 3" ¹⁵ / ₁₆ x 3" ¹⁵ / ₁₆ x ²⁵ / ₃₂ "
20x20x2	cm - 7" ⁷ / ₈ x 7" ⁷ / ₈ x ²⁵ / ₃₂ "
25x25x2	cm - 9" ²⁷ / ₃₂ x 9" ²⁷ / ₃₂ x ²⁵ / ₃₂ "
30x30x2	cm - 11" ¹³ / ₁₆ x 11" ¹³ / ₁₆ x ²⁵ / ₃₂ "
40x40x2,5	cm - 15" ³ / ₄ x 15" ³ / ₄ x ⁶³ / ₆₄ "

RETTANGOLO / RECTANGLE

8x33x2	cm - 3" ⁵ / ₃₂ x 12" ⁶³ / ₆₄ x ²⁵ / ₃₂ "
10x20x2	cm - 3" ¹⁵ / ₁₆ x 7" ⁷ / ₈ x ²⁵ / ₃₂ "
10x40x2	cm - 3" ¹⁵ / ₁₆ x 15" ³ / ₄ x ²⁵ / ₃₂ "
12x48x2	cm - 4" ²³ / ₃₂ x 18" ⁵⁷ / ₆₄ x ²⁵ / ₃₂ "
14x60x2,5	cm - 5" ³³ / ₆₄ x 23" ⁵ / ₈ x ⁶³ / ₆₄ "
15x30x2	cm - 5" ²⁹ / ₃₂ x 11" ¹³ / ₁₆ x ²⁵ / ₃₂ "
20x40x2	cm - 7" ⁷ / ₈ x 15" ³ / ₄ x ²⁵ / ₃₂ "
20x60x3	cm - 7" ⁷ / ₈ x 23" ⁵ / ₈ x 1" ³ / ₁₆
20x80x3	cm - 7" ⁷ / ₈ x 31" ¹ / ₂ x 1" ³ / ₁₆
30x60x2	cm - 11" ¹³ / ₁₆ x 23" ⁵ / ₈ x ²⁵ / ₃₂ "

ROMBO / RHOMBUS

16,5x29x2	cm - 6" ¹ / ₂ x 11" ²⁷ / ₆₄ x ²⁵ / ₃₂ "
-----------	---

ESAGONO / EXAGON

Lato 11 cm, sp. 2 cm	- Side 4" ²¹ / ₆₄ , THK ²⁵ / ₃₂ "
Lato 16 cm, sp. 2 cm	- Side 6" ¹⁹ / ₆₄ , THK ²⁵ / ₃₂ "

FINITURE / FINISHING

spazzolato/brushed

PEZZI SPECIALI / SPECIAL PIECES

pezzi per scale e battiscopa vedi pag. 108
pieces for stairs and baseboard on page 108

CUSTOM MADE

formati speciali e lati rettificati a richiesta
special formats and ground sides on request

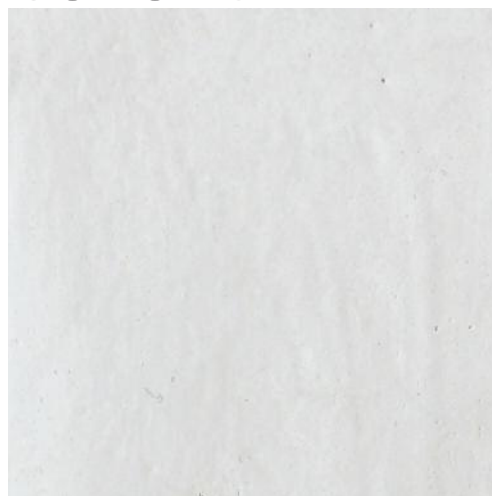

BIANCO



CIPRIA

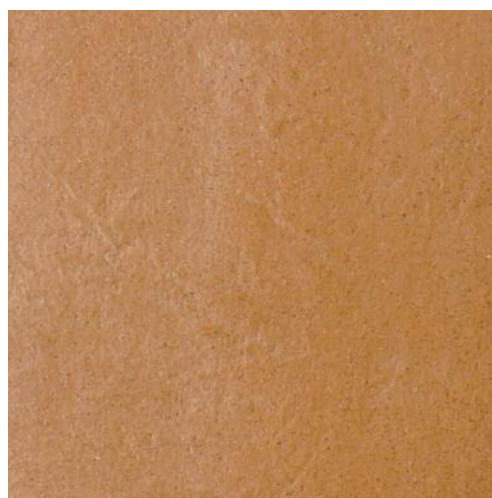

ROSSO ANTICO



ROSSO

NOTE:

cotto fatto a mano - colori e caratteristiche estetiche sono da considerarsi indicativi, misure nominali
handmade terracotta - colors and aesthetic characteristics are to be considered indicative, nominal measurements



COTTO ZERO

T

ERRE PURE

SIZES COLORS:

QUADRATO / SQUARE

10x10x2	cm - 3" ¹⁵ / ₁₆ x 3" ¹⁵ / ₁₆ x ²⁵ / ₃₂ "
20x20x2	cm - 7" ⁷ / ₈ x 7" ⁷ / ₈ x ²⁵ / ₃₂ "
25x25x2	cm - 9" ²⁷ / ₃₂ x 9" ²⁷ / ₃₂ x ²⁵ / ₃₂ "
30x30x2	cm - 11" ¹³ / ₁₆ x 11" ¹³ / ₁₆ x ²⁵ / ₃₂ "
40x40x2,5	cm - 15" ³ / ₄ x 15" ³ / ₄ x ⁶³ / ₆₄ "

RETTANGOLO / RECTANGLE

8x33x2	cm - 3" ⁵ / ₃₂ x 12" ⁶³ / ₆₄ x ²⁵ / ₃₂ "
10x20x2	cm - 3" ¹⁵ / ₁₆ x 7" ⁷ / ₈ x ²⁵ / ₃₂ "
10x40x2	cm - 3" ¹⁵ / ₁₆ x 15" ³ / ₄ x ²⁵ / ₃₂ "
12x48x2	cm - 4" ²³ / ₃₂ x 18" ⁵⁷ / ₆₄ x ²⁵ / ₃₂ "
14x60x2,5	cm - 5" ³³ / ₆₄ x 23" ⁵ / ₈ x ⁶³ / ₆₄ "
15x30x2	cm - 5" ²⁹ / ₃₂ x 11" ¹³ / ₁₆ x ²⁵ / ₃₂ "
20x40x2	cm - 7" ⁷ / ₈ x 15" ³ / ₄ x ²⁵ / ₃₂ "
20x60x3	cm - 7" ⁷ / ₈ x 23" ⁵ / ₈ x 1" ³ / ₁₆
20x80x3	cm - 7" ⁷ / ₈ x 31" ¹ / ₂ x 1" ³ / ₁₆
30x60x2	cm - 11" ¹³ / ₁₆ x 23" ⁵ / ₈ x ²⁵ / ₃₂ "

ROMBO / RHOMBUS

16,5x29x2	cm - 6" ¹ / ₂ x 11" ²⁷ / ₆₄ x ²⁵ / ₃₂ "
-----------	---

ESAGONO / EXAGON

Lato 11 cm, sp. 2 cm	- Side 4" ²¹ / ₆₄ , THK ²⁵ / ₃₂ "
Lato 16 cm, sp. 2 cm	- Side 6" ¹⁹ / ₆₄ , THK ²⁵ / ₃₂ "

FINITURE / FINISHING

spazzolato/brushed

PEZZI SPECIALI / SPECIAL PIECES

pezzi per scale e battiscopa vedi pag. 108
pieces for stairs and baseboard on page 108

CUSTOM MADE

formati speciali e lati rettificati a richiesta
special formats and ground sides on request

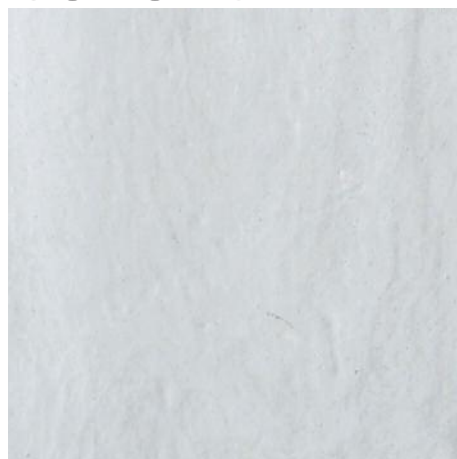

NUVOLA



POLVERE



TORTORA



FUMO

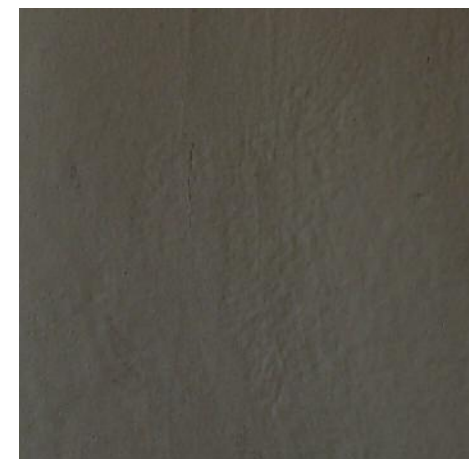

PECE

NOTE:

cotto fatto a mano - colori e caratteristiche estetiche sono da considerarsi indicative, misure nominali
handmade terracotta - colors and aesthetic characteristics are to be considered indicative, nominal measurements



COTTO ZERO

T

ERRE PURE

SIZES COLORS:

QUADRATO / SQUARE

10x10x2	cm - 3" ¹⁵ / ₁₆ x 3" ¹⁵ / ₁₆ x ²⁵ / ₃₂ "
20x20x2	cm - 7" ⁷ / ₈ x 7" ⁷ / ₈ x ²⁵ / ₃₂ "
25x25x2	cm - 9" ²⁷ / ₃₂ x 9" ²⁷ / ₃₂ x ²⁵ / ₃₂ "
30x30x2	cm - 11" ¹³ / ₁₆ x 11" ¹³ / ₁₆ x ²⁵ / ₃₂ "
40x40x2,5	cm - 15" ³ / ₄ x 15" ³ / ₄ x ⁶³ / ₆₄ "

RETTANGOLO / RECTANGLE

8x33x2	cm - 3" ⁵ / ₃₂ x 12" ⁶³ / ₆₄ x ²⁵ / ₃₂ "
10x20x2	cm - 3" ¹⁵ / ₁₆ x 7" ⁷ / ₈ x ²⁵ / ₃₂ "
10x40x2	cm - 3" ¹⁵ / ₁₆ x 15" ³ / ₄ x ²⁵ / ₃₂ "
12x48x2	cm - 4" ²³ / ₃₂ x 18" ⁵⁷ / ₆₄ x ²⁵ / ₃₂ "
14x60x2,5	cm - 5" ³³ / ₆₄ x 23" ⁵ / ₈ x ⁶³ / ₆₄ "
15x30x2	cm - 5" ²⁹ / ₃₂ x 11" ¹³ / ₁₆ x ²⁵ / ₃₂ "
20x40x2	cm - 7" ⁷ / ₈ x 15" ³ / ₄ x ²⁵ / ₃₂ "
20x60x3	cm - 7" ⁷ / ₈ x 23" ⁵ / ₈ x 1" ³ / ₁₆
20x80x3	cm - 7" ⁷ / ₈ x 31" ¹ / ₂ x 1" ³ / ₁₆
30x60x2	cm - 11" ¹³ / ₁₆ x 23" ⁵ / ₈ x ²⁵ / ₃₂ "

ROMBO / RHOMBUS

16,5x29x2	cm - 6" ¹ / ₂ x 11" ²⁷ / ₆₄ x ²⁵ / ₃₂ "
-----------	---

ESAGONO / EXAGON

Lato 11 cm, sp. 2 cm	- Side 4" ²¹ / ₆₄ , THK ²⁵ / ₃₂ "
Lato 16 cm, sp. 2 cm	- Side 6" ¹⁹ / ₆₄ , THK ²⁵ / ₃₂ "

FINITURE / FINISHING

spazzolato/brushed

PEZZI SPECIALI / SPECIAL PIECES

pezzi per scale e battiscopa vedi pag. 108
pieces for stairs and baseboard on page 108

CUSTOM MADE

formati speciali e lati rettificati a richiesta
special formats and ground sides on request



NOCE



AZZURRO



VERDE

NOTE:

cotto fatto a mano - colori e caratteristiche estetiche sono da considerarsi indicativi, misure nominali
handmade terracotta - colors and aesthetic characteristics are to be considered indicative, nominal measurements



CottoZero Terre Pure - Noce

COTTO ZERO V ENTILATO

CottoZero Ventilato reinventa il cotto ponendo l'attenzione sulla valenza tecnica e cromatica del materiale.

Una particolare lavorazione manuale delle argille permette di ottenere una superficie dal tono uniforme, dove la compattezza del nostro cotto e la finezza e la purezza dell'argilla si esprimono appieno.

Questa caratteristica è ancor più evidente nella finitura levigata che offre una superficie liscia ed omogenea.

CottoZero Ventilato reinvents terracotta by focusing on the technical and chromatic value of the material.

A particular manual processing of the clays allows us to obtain a surface with a uniform tone, where the compactness of our terracotta and the fineness and purity of the clay are fully expressed.

This feature is even more evident in the honed finish which offers a smooth and homogeneous surface.



COTTO ZERO V

ENTILATO

SIZES COLORS:

QUADRATO / SQUARE

10x10x2	cm - 3" ¹⁵ / ₁₆ x 3" ¹⁵ / ₁₆ x ²⁵ / ₃₂ "
20x20x2	cm - 7" ⁷ / ₈ x 7" ⁷ / ₈ x ²⁵ / ₃₂ "
25x25x2	cm - 9" ²⁷ / ₃₂ x 9" ²⁷ / ₃₂ x ²⁵ / ₃₂ "
30x30x2	cm - 11" ¹³ / ₁₆ x 11" ¹³ / ₁₆ x ²⁵ / ₃₂ "
40x40x2,5	cm - 15" ³ / ₄ x 15" ³ / ₄ x ⁶³ / ₆₄ "

RETTANGOLO / RECTANGLE

10x40x2	cm - 3" ¹⁵ / ₁₆ 15" ³ / ₄ x ²⁵ / ₃₂ "
12x48x2	cm - 4" ²³ / ₃₂ x 18" ⁵ / ₆₄ x ²⁵ / ₃₂ "
15x30x2	cm - 5" ²⁹ / ₃₂ x 11" ¹³ / ₁₆ x ²⁵ / ₃₂ "
20x40x2	cm - 7" ⁷ / ₈ x 15" ³ / ₄ x ²⁵ / ₃₂ "
30x60x2	cm - 11" ¹³ / ₁₆ x 23" ⁵ / ₈ x ²⁵ / ₃₂ "

ROMBO / RHOMBUS

16,5x29x2	cm - 6" ¹ / ₂ x 11" ²⁷ / ₆₄ x ²⁵ / ₃₂ "
-----------	---

ESAGONO / EXAGON

Lato 11 cm, sp. 2 cm	- Side 4" ²³ / ₆₄ , THK ²⁵ / ₃₂ "
Lato 16 cm, sp. 2 cm	- Side 6" ¹⁹ / ₆₄ , THK ²⁵ / ₃₂ "

FINITURE / FINISHING

spazzolato/levigato
brushed/smoothed

PEZZI SPECIALI / SPECIAL PIECES

pezzi per scale e battiscopa vedi pag. 108
pieces for stairs and baseboard on page 108

CUSTOM MADE

formati speciali e lati rettificati a richiesta
special formats and ground sides on request

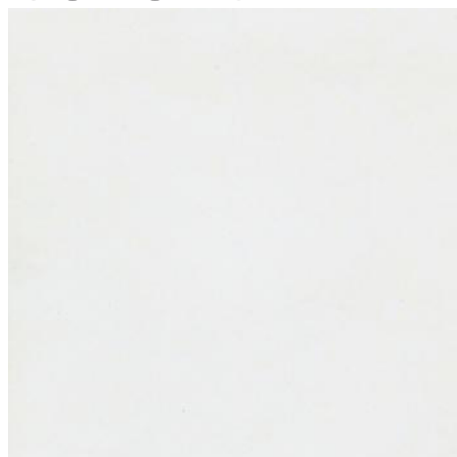

BIANCO



CIPRIA



ROSATO



ROSSO ANTICO



ROSSO

NOTE:

cotto fatto a mano - colori e caratteristiche estetiche sono da considerarsi indicativi, misure nominali
handmade terracotta - colors and aesthetic characteristics are to be considered indicative, nominal measurements



COTTO ZERO V

ENTILATO

SIZES COLORS:

QUADRATO / SQUARE

10x10x2	cm - 3" ¹⁵ / ₁₆ x 3" ¹⁵ / ₁₆ x ²⁵ / ₃₂ "
20x20x2	cm - 7" ⁷ / ₈ x 7" ⁷ / ₈ x ²⁵ / ₃₂ "
25x25x2	cm - 9" ²⁷ / ₃₂ x 9" ²⁷ / ₃₂ x ²⁵ / ₃₂ "
30x30x2	cm - 11" ¹³ / ₁₆ x 11" ¹³ / ₁₆ x ²⁵ / ₃₂ "
40x40x2,5	cm - 15" ³ / ₄ x 15" ³ / ₄ x ⁶³ / ₆₄ "

RETTANGOLO / RECTANGLE

10x40x2	cm - 3" ¹⁵ / ₁₆ 15" ³ / ₄ x ²⁵ / ₃₂ "
12x48x2	cm - 4" ²³ / ₃₂ x 18" ⁵ / ₆₄ x ²⁵ / ₃₂ "
15x30x2	cm - 5" ²⁹ / ₃₂ x 11" ¹³ / ₁₆ x ²⁵ / ₃₂ "
20x40x2	cm - 7" ⁷ / ₈ x 15" ³ / ₄ x ²⁵ / ₃₂ "
30x60x2	cm - 11" ¹³ / ₁₆ x 23" ⁵ / ₈ x ²⁵ / ₃₂ "

ROMBO / RHOMBUS

16,5x29x2	cm - 6" ¹ / ₂ x 11" ²⁷ / ₆₄ x ²⁵ / ₃₂ "
-----------	---

ESAGONO / EXAGON

Lato 11 cm, sp. 2 cm	- Side 4" ²³ / ₆₄ , THK ²⁵ / ₃₂ "
Lato 16 cm, sp. 2 cm	- Side 6" ¹⁹ / ₆₄ , THK ²⁵ / ₃₂ "

FINITURE / FINISHING

spazzolato/levigato
brushed/smoothed

PEZZI SPECIALI / SPECIAL PIECES

pezzi per scale e battiscopa vedi pag. 108
pieces for stairs and baseboard on page 108

CUSTOM MADE

formati speciali e lati rettificati a richiesta
special formats and ground sides on request



VERDE



NOCE



AZZURRO



BLU

NOTE:

cotto fatto a mano - colori e caratteristiche estetiche sono da considerarsi indicativi, misure nominali
handmade terracotta - colors and aesthetic characteristics are to be considered indicative, nominal measurements



CottoZero Ventilato - Noce

COTTO ZERO V

ENTILATO

SIZES COLORS:

QUADRATO / SQUARE

10x10x2	cm - 3" ¹⁵ / ₁₆ x 3" ¹⁵ / ₁₆ x ²⁵ / ₃₂ "
20x20x2	cm - 7" ⁷ / ₈ x 7" ⁷ / ₈ x ²⁵ / ₃₂ "
25x25x2	cm - 9" ²⁷ / ₃₂ x 9" ²⁷ / ₃₂ x ²⁵ / ₃₂ "
30x30x2	cm - 11" ¹³ / ₁₆ x 11" ¹³ / ₁₆ x ²⁵ / ₃₂ "
40x40x2,5	cm - 15" ³ / ₄ x 15" ³ / ₄ x ⁶³ / ₆₄ "

RETTANGOLO / RECTANGLE

10x40x2	cm - 3" ¹⁵ / ₁₆ 15" ³ / ₄ x ²⁵ / ₃₂ "
12x48x2	cm - 4" ²³ / ₃₂ x 18" ⁵ / ₆₄ x ²⁵ / ₃₂ "
15x30x2	cm - 5" ²⁹ / ₃₂ x 11" ¹³ / ₁₆ x ²⁵ / ₃₂ "
20x40x2	cm - 7" ⁷ / ₈ x 15" ³ / ₄ x ²⁵ / ₃₂ "
30x60x2	cm - 11" ¹³ / ₁₆ x 23" ⁵ / ₈ x ²⁵ / ₃₂ "

ROMBO / RHOMBUS

16,5x29x2	cm - 6" ¹ / ₂ x 11" ²⁷ / ₆₄ x ²⁵ / ₃₂ "
-----------	---

ESAGONO / EXAGON

Lato 11 cm, sp. 2 cm	- Side 4" ²³ / ₆₄ , THK ²⁵ / ₃₂ "
Lato 16 cm, sp. 2 cm	- Side 6" ¹⁹ / ₆₄ , THK ²⁵ / ₃₂ "

FINITURE / FINISHING

spazzolato/levigato
brushed/smoothed

PEZZI SPECIALI / SPECIAL PIECES

pezzi per scale e battiscopa vedi pag. 106
pieces for stairs and baseboard on page 106

CUSTOM MADE

formati speciali e lati rettificati a richiesta
special formats and ground sides on request

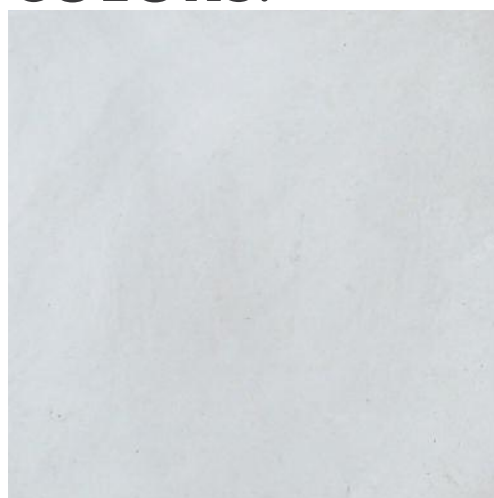

NUVOLA



TORTORA



FUMO



PECE

NOTE:

cotto fatto a mano - colori e caratteristiche estetiche sono da considerarsi indicativi, misure nominali
handmade terracotta - colors and aesthetic characteristics are to be considered indicative, nominal measurements



COTTO ZERO P IETRAME

Dall'incontro tra le nostre argille finemente macinate e una particolare selezione di pietrame nasce un cotto unico.

Gli inerti, selezionati in base al colore e rimacinati in azienda per ottenere la corretta granulometria, vengono aggiunti all'impasto, in questo modo, dopo la cottura e la finitura superficiale del pezzo, i piccoli frammenti appaiono in modo casuale, punteggiando la superficie.

Queste inclusioni, dalle diverse dimensioni e colorazioni che vanno dall'avorio al nocciola e fino all'aranciato, arricchiscono la superficie di eleganti vibrazioni cromatiche.

CottoZero Pietrame è un altro cotto che nasce dall'esperienza della tradizione e, in questa collezione, si reinventa, diventando prezioso interprete dello stile contemporaneo.

A unique terracotta is born from the encounter between our finely ground clays and a particular selection of stones.

The aggregates, selected based on color and re-ground in the company to obtain the correct grain size, are added to the mixture, in this way, after firing and surface finishing of the piece, the small fragments appear randomly, dotting the surface.

These inclusions, of different sizes and colors; from ivory to hazelnut to orange, they enrich the surface with elegant chromatic vibrations.

CottoZero Pietrame is another terracotta that comes from the experience of tradition and, in this collection, reinvents itself, becoming a precious interpreter of contemporary style

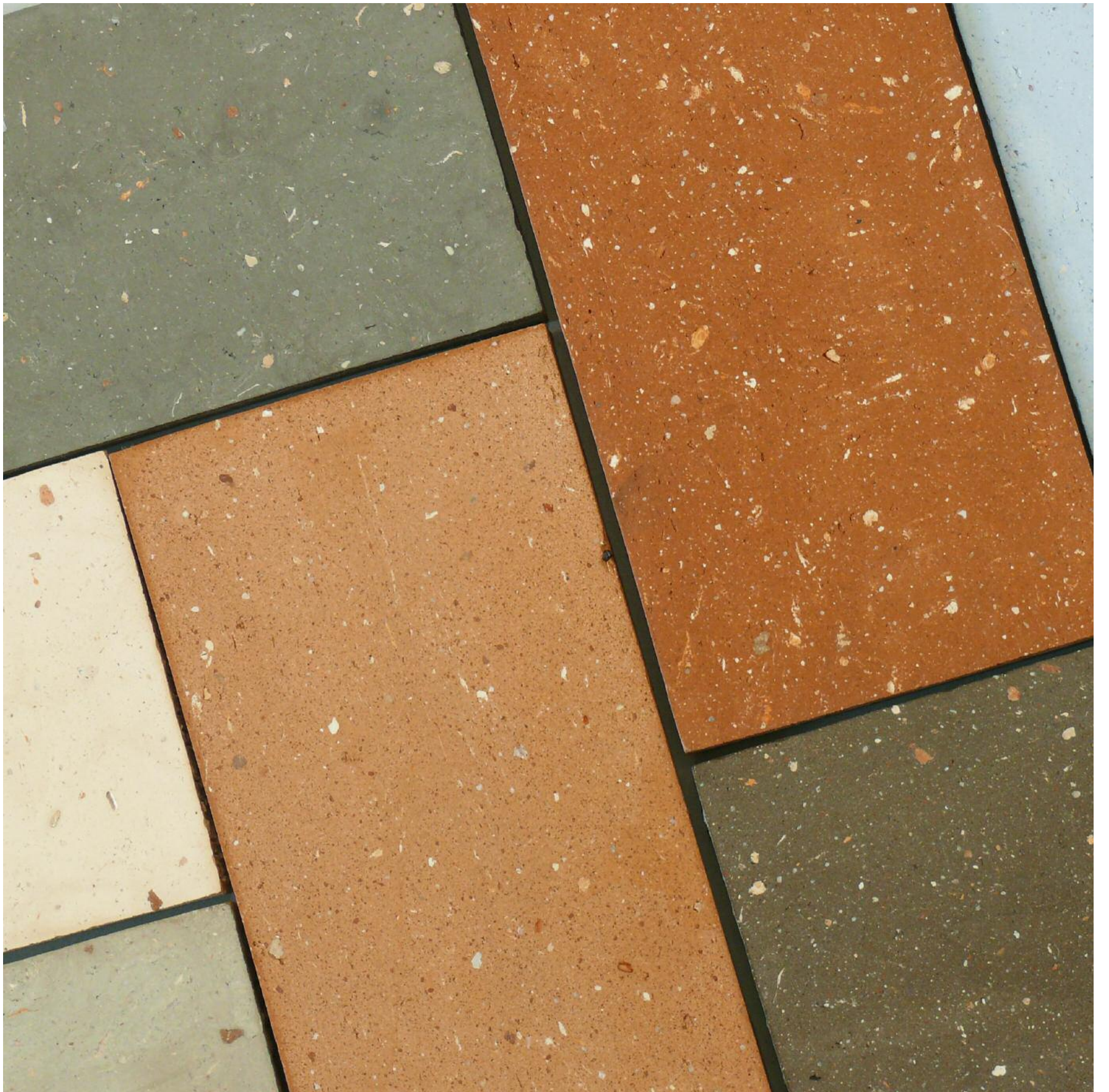

COTTO ZERO P

IETRA

SIZES COLORS:

QUADRATO / SQUARE

10x10x2	cm - 3" ¹⁵ / ₁₆ x 3" ¹⁵ / ₁₆ x ²⁵ / ₃₂ "
20x20x2	cm - 7" ⁷ / ₈ x 7" ⁷ / ₈ x ²⁵ / ₃₂ "
25x25x2	cm - 9" ²⁷ / ₃₂ x 9" ²⁷ / ₃₂ x ²⁵ / ₃₂ "
30x30x2	cm - 11" ¹³ / ₁₆ x 11" ¹³ / ₁₆ x ²⁵ / ₃₂ "
40x40x2,5	cm - 15" ³ / ₄ x 15" ³ / ₄ x ⁶³ / ₆₄ "

RETTANGOLO / RECTANGLE

8x33x2	cm - 3" ⁵ / ₃₂ x 12" ⁶³ / ₆₄ x ²⁵ / ₃₂ "
10x20x2	cm - 3" ¹⁵ / ₁₆ x 7" ⁷ / ₈ x ²⁵ / ₃₂ "
10x40x2	cm - 3" ¹⁵ / ₁₆ x 15" ³ / ₄ x ²⁵ / ₃₂ "
12x48x2	cm - 4" ²³ / ₃₂ x 18" ⁵⁷ / ₆₄ x ²⁵ / ₃₂ "
14x60x2,5	cm - 5" ³³ / ₆₄ x 23" ⁵ / ₈ x ⁶³ / ₆₄ "
15x30x2	cm - 5" ²⁹ / ₃₂ x 11" ¹³ / ₁₆ x ²⁵ / ₃₂ "
20x40x2	cm - 7" ⁷ / ₈ x 15" ³ / ₄ x ²⁵ / ₃₂ "
20x60x3	cm - 7" ⁷ / ₈ x 23" ⁵ / ₈ x 1" ³ / ₁₆
20x80x3	cm - 7" ⁷ / ₈ x 31" ¹ / ₂ x 1" ³ / ₁₆
30x60x2	cm - 11" ¹³ / ₁₆ x 23" ⁵ / ₈ x ²⁵ / ₃₂ "

ROMBO / RHOMBUS

16,5x29x2	cm - 6" ¹ / ₂ x 11" ²⁷ / ₆₄ x ²⁵ / ₃₂ "
-----------	---

ESAGONO / EXAGON

Lato 11 cm, sp. 2 cm	- Side 4" ²¹ / ₆₄ , THK ²⁵ / ₃₂ "
Lato 16 cm, sp. 2 cm	- Side 6" ¹⁹ / ₆₄ , THK ²⁵ / ₃₂ "

FINITURE / FINISHING

levigato/smoothed

PEZZI SPECIALI / SPECIAL PIECES

pezzi per scale e battiscopa vedi pag. 108
pieces for stairs and baseboard on page 108

CUSTOM MADE

formati speciali e lati rettificati a richiesta
special formats and ground sides on request



BIANCO



GRIGIO PERLA

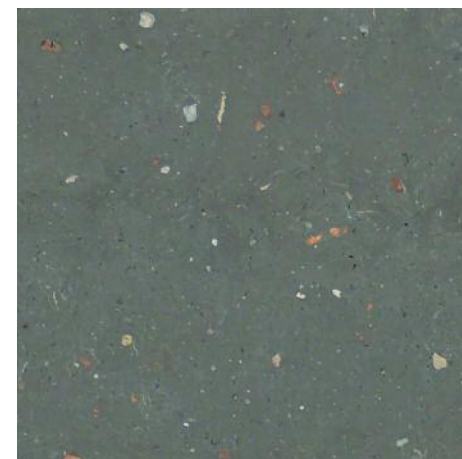

PECE

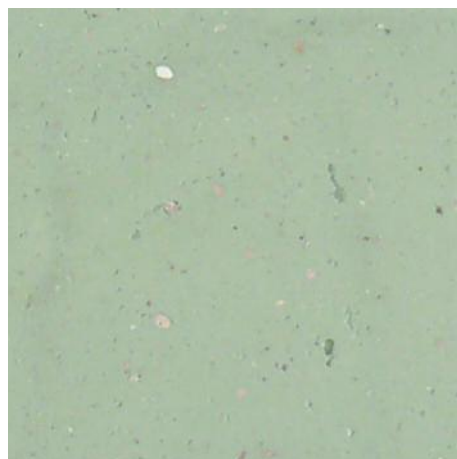

VERDE

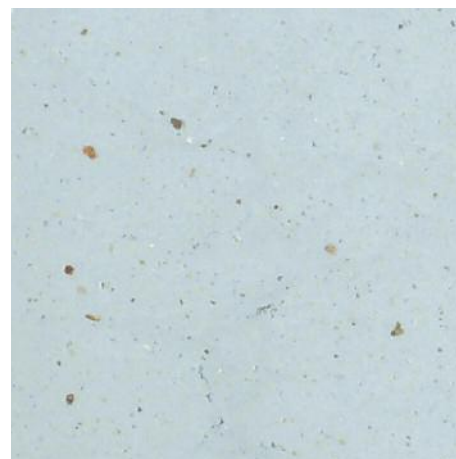

AZZURRO

NOTE:

cotto fatto a mano - colori e caratteristiche estetiche sono da considerarsi indicative, misure nominali
handmade terracotta - colors and aesthetic characteristics are to be considered indicative, nominal measurements



COTTO ZERO P

IETRAME

SIZES COLORS:

QUADRATO / SQUARE

10x10x2	cm - 3" ¹⁵ / ₁₆ x 3" ¹⁵ / ₁₆ x ²⁵ / ₃₂ "
20x20x2	cm - 7" ⁷ / ₈ x 7" ⁷ / ₈ x ²⁵ / ₃₂ "
25x25x2	cm - 9" ²⁷ / ₃₂ x 9" ²⁷ / ₃₂ x ²⁵ / ₃₂ "
30x30x2	cm - 11" ¹³ / ₁₆ x 11" ¹³ / ₁₆ x ²⁵ / ₃₂ "
40x40x2,5	cm - 15" ³ / ₄ x 15" ³ / ₄ x ⁶³ / ₆₄ "

RETTANGOLO / RECTANGLE

8x33x2	cm - 3" ⁵ / ₃₂ x 12" ⁶³ / ₆₄ x ²⁵ / ₃₂ "
10x20x2	cm - 3" ¹⁵ / ₁₆ x 7" ⁷ / ₈ x ²⁵ / ₃₂ "
10x40x2	cm - 3" ¹⁵ / ₁₆ x 15" ³ / ₄ x ²⁵ / ₃₂ "
12x48x2	cm - 4" ²³ / ₃₂ x 18" ⁵⁷ / ₆₄ x ²⁵ / ₃₂ "
14x60x2,5	cm - 5" ³³ / ₆₄ x 23" ⁵ / ₈ x ⁶³ / ₆₄ "
15x30x2	cm - 5" ²⁹ / ₃₂ x 11" ¹³ / ₁₆ x ²⁵ / ₃₂ "
20x40x2	cm - 7" ⁷ / ₈ x 15" ³ / ₄ x ²⁵ / ₃₂ "
20x60x3	cm - 7" ⁷ / ₈ x 23" ⁵ / ₈ x 1" ³ / ₁₆
20x80x3	cm - 7" ⁷ / ₈ x 31" ¹ / ₂ x 1" ³ / ₁₆
30x60x2	cm - 11" ¹³ / ₁₆ x 23" ⁵ / ₈ x ²⁵ / ₃₂ "

ROMBO / RHOMBUS

16,5x29x2	cm - 6" ¹ / ₂ x 11" ²⁷ / ₆₄ x ²⁵ / ₃₂ "
-----------	---

ESAGONO / EXAGON

Lato 11 cm, sp. 2 cm	- Side 4" ²¹ / ₆₄ , THK ²⁵ / ₃₂ "
Lato 16 cm, sp. 2 cm	- Side 6" ¹⁹ / ₆₄ , THK ²⁵ / ₃₂ "

FINITURE / FINISHING

levigato/smoothed

PEZZI SPECIALI / SPECIAL PIECES

pezzi per scale e battiscopa vedi pag. 108
pieces for stairs and baseboard on page 108

CUSTOM MADE

formati speciali e lati rettificati a richiesta
special formats and ground sides on request

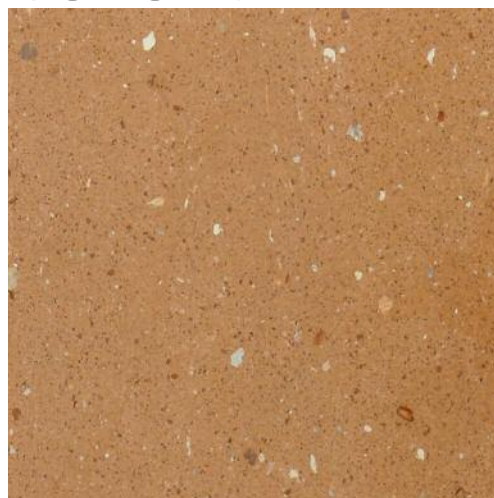

ROSSO ANTICO

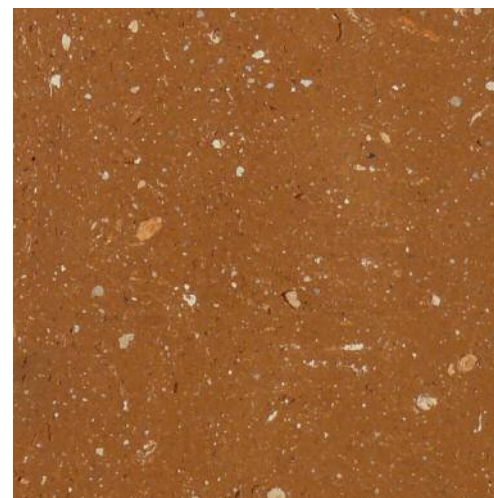

ROSSO

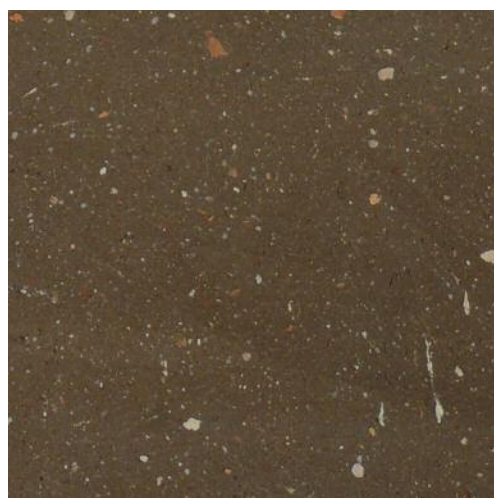

NOCE

NOTE:

cotto fatto a mano - colori e caratteristiche estetiche sono da considerarsi indicative, misure nominali
handmade terracotta - colors and aesthetic characteristics are to be considered indicative, nominal measurements



COTTO ZERO V ARIEGATO

Il CottoZero Variiegato nasce da una tecnica tradizionale dell'area lombardo-piemontese, tanto da essere conosciuta nella sua variante rossa variiegata di giallo anche come "medone lombardo".

La bellezza estetica di questi cotti è riproposta sia nelle colorazioni classiche che in declinazioni più originali ed ardite, giocate a volte su forti contrasti e a volte su morbidi passaggi di tono.

CottoZero Variiegato was born from a traditional technique of the Lombardy-Piedmont area, so much so that it is also known in its red variant variegated with yellow as "medone lombardo".

The aesthetic beauty of these terracotta tiles is proposed both in classic colors and in more original and daring variations, sometimes played on strong contrasts and sometimes on soft transitions of tone.

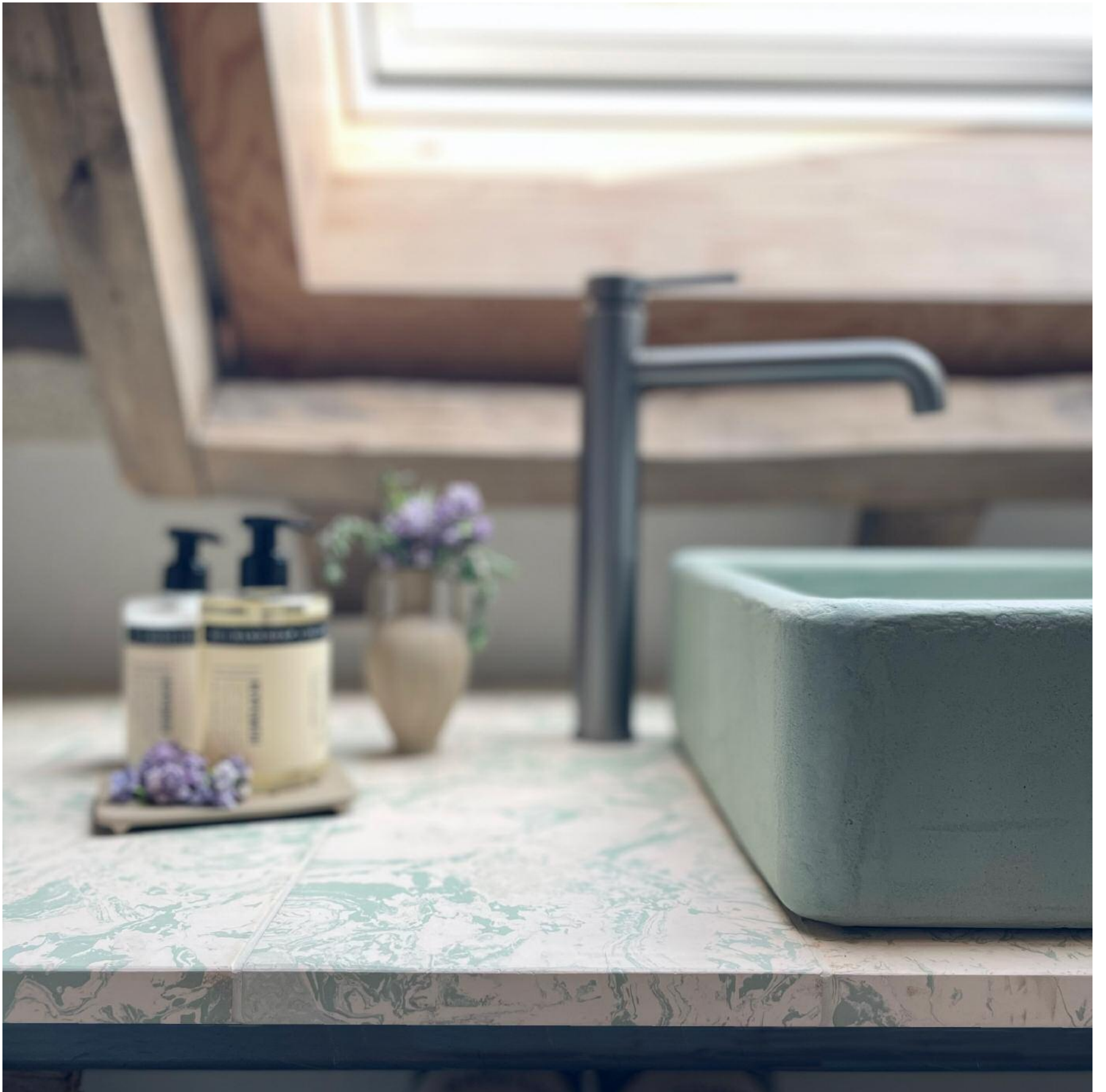

COTTO ZERO V

ARIEGATO

SIZES COLORS:

QUADRATO / SQUARE

10x10x2	cm - 3" ¹⁵ / ₁₆ x 3" ¹⁵ / ₁₆ x ²⁵ / ₃₂ "
20x20x2	cm - 7" ⁷ / ₈ x 7" ⁷ / ₈ x ²⁵ / ₃₂ "
25x25x2	cm - 9" ²⁷ / ₃₂ x 9" ²⁷ / ₃₂ x ²⁵ / ₃₂ "
30x30x2	cm - 11" ¹³ / ₁₆ x 11" ¹³ / ₁₆ x ²⁵ / ₃₂ "
40x40x2,5	cm - 15" ³ / ₄ x 15" ³ / ₄ x ⁶³ / ₆₄ "

RETTANGOLO / RECTANGLE

10x40x2	cm - 3" ¹⁵ / ₁₆ 15" ³ / ₄ x ²⁵ / ₃₂ "
12x48x2	cm - 4" ²³ / ₃₂ x 18" ⁵ / ₆₄ x ²⁵ / ₃₂ "
15x30x2	cm - 5" ²⁹ / ₃₂ x 11" ¹³ / ₁₆ x ²⁵ / ₃₂ "
20x40x2	cm - 7" ⁷ / ₈ x 15" ³ / ₄ x ²⁵ / ₃₂ "
30x60x2	cm - 11" ¹³ / ₁₆ x 23" ⁵ / ₈ x ²⁵ / ₃₂ "

ROMBO / RHOMBUS

16,5x29x2	cm - 6" ¹ / ₂ x 11" ²⁷ / ₆₄ x ²⁵ / ₃₂ "
-----------	---

ESAGONO / EXAGON

Lato 11 cm, sp. 2 cm	- Side 4" ²³ / ₆₄ , THK ²⁵ / ₃₂ "
Lato 16 cm, sp. 2 cm	- Side 6" ¹⁹ / ₆₄ , THK ²⁵ / ₃₂ "

FINITURE / FINISHING

levigato a mano / smoothed by hand

PEZZI SPECIALI / SPECIAL PIECES

pezzi per scale e battiscopa vedi pag. 108
pieces for stairs and baseboard on page 108

CUSTOM MADE

formati speciali e lati rettificati a richiesta
special formats and ground sides on request



BIANCO VARIEGATO CIPRIA

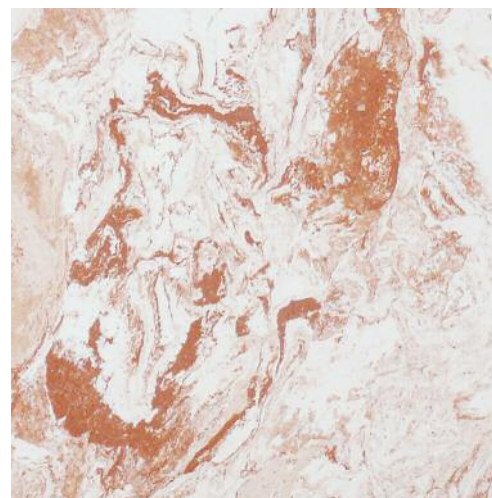

BIANCO VARIEGATO ROSSO



ROSSO VARIEGATO GIALLO

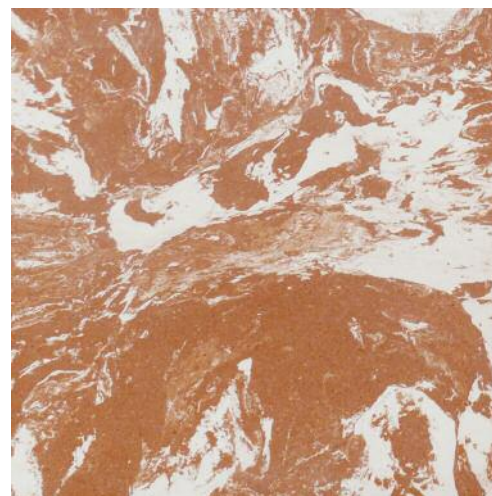

ROSSO VARIEGATO BIANCO

NOTE:

cotto fatto a mano - colori e caratteristiche estetiche sono da considerarsi indicativi, misure nominali
handmade terracotta - colors and aesthetic characteristics are to be considered indicative, nominal measurements



COTTO ZERO V

ARIEGATO

SIZES COLORS:

QUADRATO / SQUARE

10x10x2 cm - 3" ¹⁵/₁₆ x 3" ¹⁵/₁₆ x ²⁵/₃₂"
 20x20x2 cm - 7" ⁷/₈ x 7" ⁷/₈ x ²⁵/₃₂"
 25x25x2 cm - 9" ²⁷/₃₂ x 9" ²⁷/₃₂ x ²⁵/₃₂"
 30x30x2 cm - 11" ¹³/₁₆ x 11" ¹³/₁₆ x ²⁵/₃₂"
 40x40x2,5 cm - 15" ³/₄ x 15" ³/₄ x ⁶³/₆₄"

RETTANGOLO / RECTANGLE

10x40x2 cm - 3" ¹⁵/₁₆ x 15" ³/₄ x ²⁵/₃₂"
 12x48x2 cm - 4" ²³/₃₂ x 18" ⁵/₆₄ x ²⁵/₃₂"
 15x30x2 cm - 5" ²⁹/₃₂ x 11" ¹³/₁₆ x ²⁵/₃₂"
 20x40x2 cm - 7" ⁷/₈ x 15" ³/₄ x ²⁵/₃₂"
 30x60x2 cm - 11" ¹³/₁₆ x 23" ⁵/₈ x ²⁵/₃₂"

ROMBO / RHOMBUS

16,5x29x2 cm - 6" ¹/₂ x 11" ²⁷/₆₄ x ²⁵/₃₂"

ESAGONO / EXAGON

Lato 11 cm, sp. 2 cm - Side 4" ²³/₆₄, THK ²⁵/₃₂"
 Lato 16 cm, sp. 2 cm - Side 6" ¹⁹/₆₄, THK ²⁵/₃₂"

FINITURE / FINISHING

levigato a mano / smoothed by hand

PEZZI SPECIALI / SPECIAL PIECES

pezzi per scale e battiscopa vedi pag. 108
 pieces for stairs and baseboard on page 108

CUSTOM MADE

formati speciali e lati rettificati a richiesta
 special formats and ground sides on request



BIANCO VARIEGATO TORTORA



TORTORA VARIEGATO BIANCO



FUMO VARIEGATO PERLA



BIANCO VARIEGATO PECE

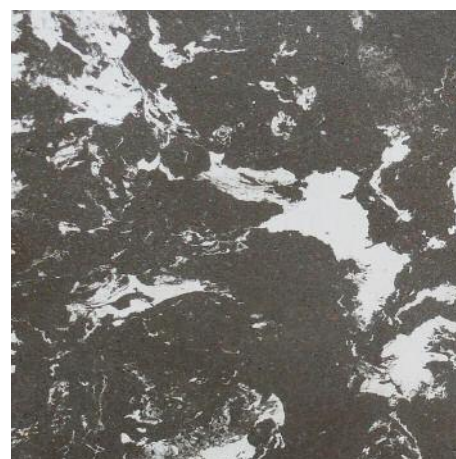

PECE VARIEGATO BIANCO

NOTE:

cotto fatto a mano - colori e caratteristiche estetiche sono da considerarsi indicativi, misure nominali
 handmade terracotta - colors and aesthetic characteristics are to be considered indicative, nominal measurements



COTTO ZERO V

ARIEGATO

SIZES COLORS:

QUADRATO / SQUARE

10x10x2	cm - 3" ¹⁵ / ₁₆ x 3" ¹⁵ / ₁₆ x ²⁵ / ₃₂ "
20x20x2	cm - 7" ⁷ / ₈ x 7" ⁷ / ₈ x ²⁵ / ₃₂ "
25x25x2	cm - 9" ²⁷ / ₃₂ x 9" ²⁷ / ₃₂ x ²⁵ / ₃₂ "
30x30x2	cm - 11" ¹³ / ₁₆ x 11" ¹³ / ₁₆ x ²⁵ / ₃₂ "
40x40x2,5	cm - 15" ³ / ₄ x 15" ³ / ₄ x ⁶³ / ₆₄ "

RETTANGOLO / RECTANGLE

10x40x2	cm - 3" ¹⁵ / ₁₆ 15" ³ / ₄ x ²⁵ / ₃₂ "
12x48x2	cm - 4" ²³ / ₃₂ x 18" ⁵ / ₆₄ x ²⁵ / ₃₂ "
15x30x2	cm - 5" ²⁹ / ₃₂ x 11" ¹³ / ₁₆ x ²⁵ / ₃₂ "
20x40x2	cm - 7" ⁷ / ₈ x 15" ³ / ₄ x ²⁵ / ₃₂ "
30x60x2	cm - 11" ¹³ / ₁₆ x 23" ⁵ / ₈ x ²⁵ / ₃₂ "

ROMBO / RHOMBUS

16,5x29x2	cm - 6" ¹ / ₂ x 11" ²⁷ / ₆₄ x ²⁵ / ₃₂ "
-----------	---

ESAGONO / EXAGON

Lato 11 cm, sp. 2 cm	- Side 4" ²³ / ₆₄ , THK ²⁵ / ₃₂ "
Lato 16 cm, sp. 2 cm	- Side 6" ¹⁹ / ₆₄ , THK ²⁵ / ₃₂ "

FINITURE / FINISHING

levigato a mano / smoothed by hand

PEZZI SPECIALI / SPECIAL PIECES

pezzi per scale e battiscopa vedi pag. 108
pieces for stairs and baseboard on page 108

CUSTOM MADE

formati speciali e lati rettificati a richiesta
special formats and ground sides on request

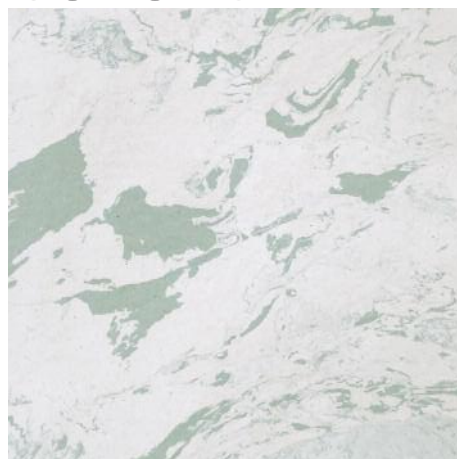

BIANCO VARIEGATO VERDE

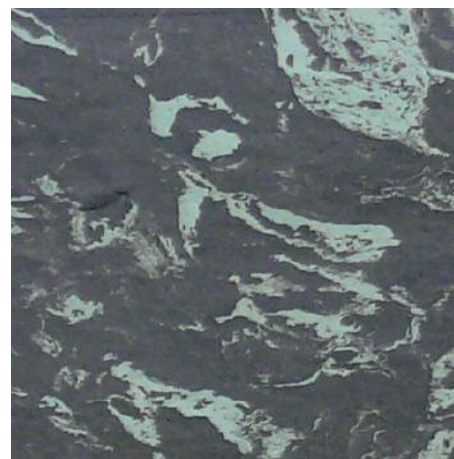

PECE VARIEGATO VERDE



BIANCO VARIEGATO AZZURRO

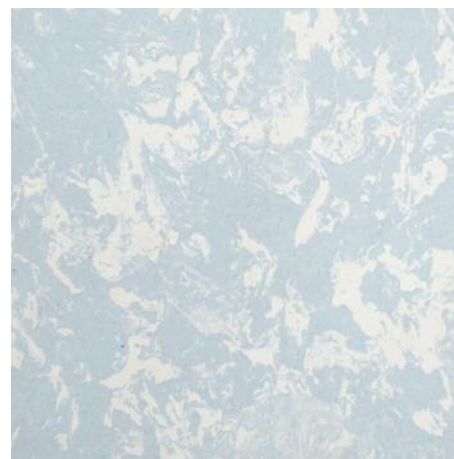

AZZURRO VARIEGATO BIANCO



PECE VARIEGATO AZZURRO

NOTE:

cotto fatto a mano - colori e caratteristiche estetiche sono da considerarsi indicativi, misure nominali
handmade terracotta - colors and aesthetic characteristics are to be considered indicative, nominal measurements



COTTO ZERO V

ARIEGATO

SIZES COLORS:

QUADRATO / SQUARE

10x10x2	cm - 3" ¹⁵ / ₁₆ x 3" ¹⁵ / ₁₆ x ²⁵ / ₃₂ "
20x20x2	cm - 7" ⁷ / ₈ x 7" ⁷ / ₈ x ²⁵ / ₃₂ "
25x25x2	cm - 9" ²⁷ / ₃₂ x 9" ²⁷ / ₃₂ x ²⁵ / ₃₂ "
30x30x2	cm - 11" ¹³ / ₁₆ x 11" ¹³ / ₁₆ x ²⁵ / ₃₂ "
40x40x2,5	cm - 15" ³ / ₄ x 15" ³ / ₄ x ⁶³ / ₆₄ "

RETTANGOLO / RECTANGLE

10x40x2	cm - 3" ¹⁵ / ₁₆ 15" ³ / ₄ x ²⁵ / ₃₂ "
12x48x2	cm - 4" ²³ / ₃₂ x 18" ⁵ / ₆₄ x ²⁵ / ₃₂ "
15x30x2	cm - 5" ²⁹ / ₃₂ x 11" ¹³ / ₁₆ x ²⁵ / ₃₂ "
20x40x2	cm - 7" ⁷ / ₈ x 15" ³ / ₄ x ²⁵ / ₃₂ "
30x60x2	cm - 11" ¹³ / ₁₆ x 23" ⁵ / ₈ x ²⁵ / ₃₂ "

ROMBO / RHOMBUS

16,5x29x2	cm - 6" ¹ / ₂ x 11" ²⁷ / ₆₄ x ²⁵ / ₃₂ "
-----------	---

ESAGONO / EXAGON

Lato 11 cm, sp. 2 cm	- Side 4" ²³ / ₆₄ , THK ²⁵ / ₃₂ "
Lato 16 cm, sp. 2 cm	- Side 6" ¹⁹ / ₆₄ , THK ²⁵ / ₃₂ "

FINITURE / FINISHING

levigato a mano / smoothed by hand

PEZZI SPECIALI / SPECIAL PIECES

pezzi per scale e battiscopa vedi pag. 108
pieces for stairs and baseboard on page 108

CUSTOM MADE

formati speciali e lati rettificati a richiesta
special formats and ground sides on request



ROSSO VARIEGATO AZZURRO

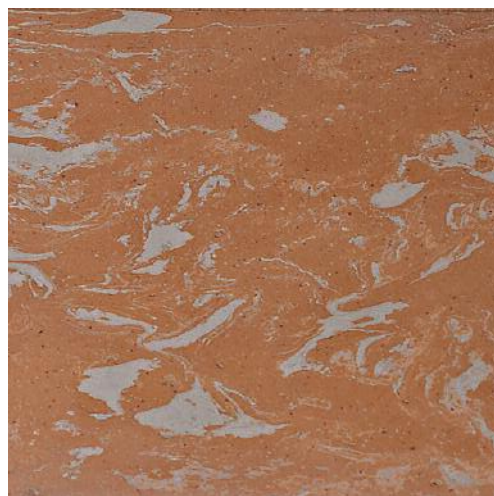

ROSSO VARIEGATO TORTORA

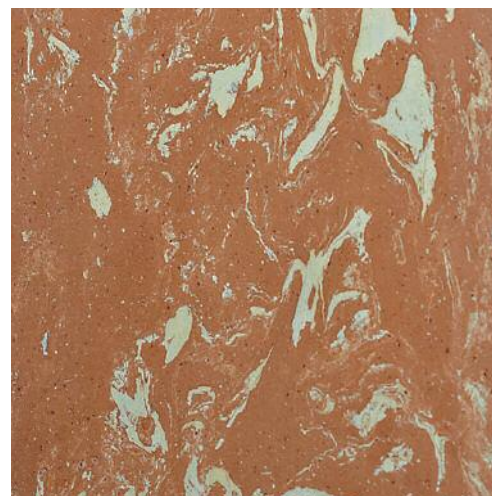

ROSSO VARIEGATO VERDE

NOTE:

cotto fatto a mano - colori e caratteristiche estetiche sono da considerarsi indicativi, misure nominali
handmade terracotta - colors and aesthetic characteristics are to be considered indicative, nominal measurements



COTTO ZERO V

ARIEGATO

SIZES COLORS:

QUADRATO / SQUARE

10x10x2	cm - 3" ¹⁵ / ₁₆ x 3" ¹⁵ / ₁₆ x ²⁵ / ₃₂ "
20x20x2	cm - 7" ⁷ / ₈ x 7" ⁷ / ₈ x ²⁵ / ₃₂ "
25x25x2	cm - 9" ²⁷ / ₃₂ x 9" ²⁷ / ₃₂ x ²⁵ / ₃₂ "
30x30x2	cm - 11" ¹³ / ₁₆ x 11" ¹³ / ₁₆ x ²⁵ / ₃₂ "
40x40x2,5	cm - 15" ³ / ₄ x 15" ³ / ₄ x ⁶³ / ₆₄ "

RETTANGOLO / RECTANGLE

10x40x2	cm - 3" ¹⁵ / ₁₆ 15" ³ / ₄ x ²⁵ / ₃₂ "
12x48x2	cm - 4" ²³ / ₃₂ x 18" ⁵ / ₆₄ x ²⁵ / ₃₂ "
15x30x2	cm - 5" ²⁹ / ₃₂ x 11" ¹³ / ₁₆ x ²⁵ / ₃₂ "
20x40x2	cm - 7" ⁷ / ₈ x 15" ³ / ₄ x ²⁵ / ₃₂ "
30x60x2	cm - 11" ¹³ / ₁₆ x 23" ⁵ / ₈ x ²⁵ / ₃₂ "

ROMBO / RHOMBUS

16,5x29x2	cm - 6" ¹ / ₂ x 11" ²⁷ / ₆₄ x ²⁵ / ₃₂ "
-----------	---

ESAGONO / EXAGON

Lato 11 cm, sp. 2 cm	- Side 4" ²³ / ₆₄ , THK ²⁵ / ₃₂ "
Lato 16 cm, sp. 2 cm	- Side 6" ¹⁹ / ₆₄ , THK ²⁵ / ₃₂ "

FINITURE / FINISHING

levigato a mano / smoothed by hand

PEZZI SPECIALI / SPECIAL PIECES

pezzi per scale e battiscopa vedi pag. 108
pieces for stairs and baseboard on page 108

CUSTOM MADE

formati speciali e lati rettificati a richiesta
special formats and ground sides on request

NOTE:

cotto fatto a mano - colori e caratteristiche estetiche sono da considerarsi indicative, misure nominali
handmade terracotta - colors and aesthetic characteristics are to be considered indicative, nominal measurements



NOCE VARIEGATO BIANCO

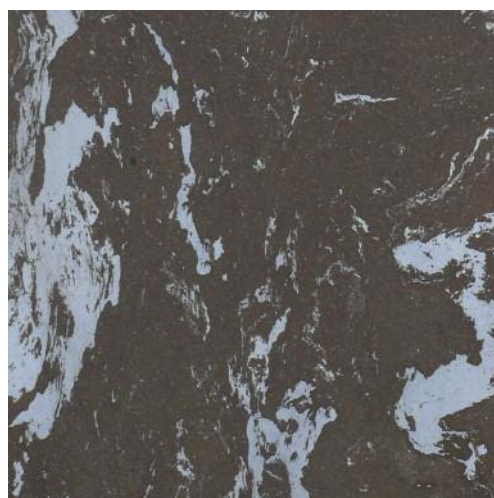

NOCE VARIEGATO AZZURRO



CottoZero Variegato - Noce variegato Bianco



ARIEGATI & SOLID COLORS

TINTE UNITE IN ABBINAMENTO / SOLID COLORS IN COMBINATION

La particolare lavorazione "a pane" dei cotti variegati ne caratterizza la superficie, per questo, per le eventuali tinte unite da usare in accostamento viene utilizzata la stessa tecnica.

The particular "bread" processing of the Sciruss terracotta tiles characterizes the surface, for this reason the same technique is used for any solid colors to be used in combination.

			
ROSSO VARIEGATO BIANCO	ROSSO VARIEGATO GIALLO	ROSSO VARIEGATO VERDE	ROSSO VARIEGATO AZZURRO
			
VENTILATO ROSSO	VENTILATO ROSSO	VENTILATO ROSSO	VENTILATO ROSSO
			
VENTILATO BIANCO	VENTILATO CIPRIA	VENTILATO VERDE	VENTILATO AZZURRO
			
BIANCO VARIEGATO CIPRIA	BIANCO VARIEGATO ROSSO	BIANCO VARIEGATO TORTORA	BIANCO VARIEGATO PECE
			
VENTILATO BIANCO	VENTILATO BIANCO	VENTILATO BIANCO	VENTILATO BIANCO
			
VENTILATO CIPRIA	VENTILATO ROSSO	VENTILATO TORTORA	VENTILATO PECE



PECE VARIEGATO BIANCO

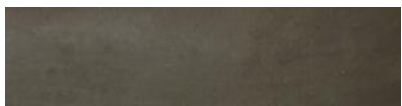

VENTILATO PECE



VENTILATO BIANCO



PECE VARIEGATO AZZURRO



VENTILATO PECE



VENTILATO AZZURRO



PECE VARIEGATO VERDE



VENTILATO PECE



VENTILATO VERDE

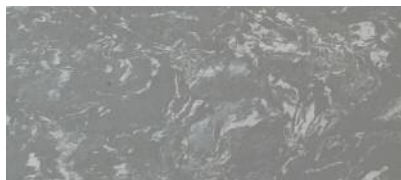

FUMO VARIEGATO PERLA



VENTILATO FUMO



VENTILATO PERLA*



ROSSO VARIEGATO TORTORA



VENTILATO ROSSO



VENTILATO TORTORA



NOCE VARIEGATO BIANCO



VENTILATO NOCE



VENTILATO BIANCO

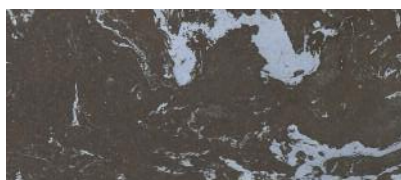

NOCE VARIEGATO AZZURRO



VENTILATO NOCE



VENTILATO AZZURRO



BIANCO VARIEGATO VERDE

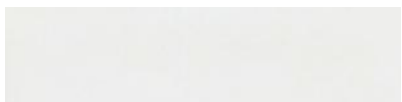

VENTILATO BIANCO



VENTILATO VERDE



BIANCO VARIEGATO AZZURRO

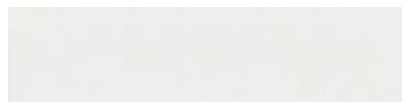

VENTILATO BIANCO



VENTILATO AZZURRO



AZZURRO VARIEGATO BIANCO

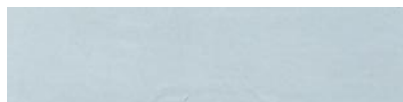

VENTILATO AZZURRO

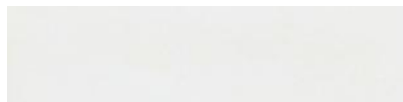

VENTILATO BIANCO



TORTORA VARIEGATO BIANCO



VENTILATO TORTORA

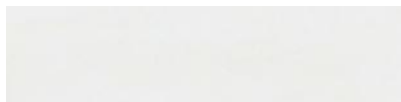

VENTILATO BIANCO

* prodotto speciale realizzato su richiesta / special product made on request

COTTO ZERO S CIRUSS

Il CottoZero Sciruss, sublima la bellezza del Cotto Variegato, facendo convivere nelle sue sfumature tre o più colorazioni di argilla.

I toni, opportunamente scelti e bilanciati, danno origine a superfici articolate e armoniose dove i colori si rincorrono e si miscelano con un incessante movimento, ricordando la bellezza di certe composizioni musicali.

The CottoZero Sciruss sublimates the beauty of variegated Cotto, making three or more clay colors coexist in its shades.

The tones, appropriately chosen and balanced, give rise to articulated and harmonious surfaces where the colors chase each other and mix with an incessant movement, recalling the beauty of certain musical compositions.



**COTTO
ZERO**

S

CIRUSS

SIZES COLORS:

QUADRATO / SQUARE

10x10x2	cm - 3" ¹⁵ / ₁₆ x 3" ¹⁵ / ₁₆ x ²⁵ / ₃₂ "
20x20x2	cm - 7" ⁷ / ₈ x 7" ⁷ / ₈ x ²⁵ / ₃₂ "
25x25x2	cm - 9" ²⁷ / ₃₂ x 9" ²⁷ / ₃₂ x ²⁵ / ₃₂ "
30x30x2	cm - 11" ¹³ / ₁₆ x 11" ¹³ / ₁₆ x ²⁵ / ₃₂ "
40x40x2,5	cm - 15" ³ / ₄ x 15" ³ / ₄ x ⁶³ / ₆₄ "

RETTANGOLO / RECTANGLE

10x40x2	cm - 3" ¹⁵ / ₁₆ 15" ³ / ₄ x ²⁵ / ₃₂ "
12x48x2	cm - 4" ²³ / ₃₂ x 18" ⁵ / ₆₄ x ²⁵ / ₃₂ "
15x30x2	cm - 5" ²⁹ / ₃₂ x 11" ¹³ / ₁₆ x ²⁵ / ₃₂ "
20x40x2	cm - 7" ⁷ / ₈ x 15" ³ / ₄ x ²⁵ / ₃₂ "
30x60x2	cm - 11" ¹³ / ₁₆ x 23" ⁵ / ₈ x ²⁵ / ₃₂ "

ROMBO / RHOMBUS

16,5x29x2	cm - 6" ¹ / ₂ x 11" ²⁷ / ₆₄ x ²⁵ / ₃₂ "
-----------	---

ESAGONO / EXAGON

Lato 11 cm, sp. 2 cm	- Side 4" ²³ / ₆₄ , THK ²⁵ / ₃₂ "
Lato 16 cm, sp. 2 cm	- Side 6" ¹⁹ / ₆₄ , THK ²⁵ / ₃₂ "

FINITURE / FINISHING

levigato a mano / smoothed by hand

PEZZI SPECIALI / SPECIAL PIECES

pezzi per scale e battiscopa vedi pag. 108
pieces for stairs and baseboard on page 108

CUSTOM MADE

formati speciali e lati rettificati a richiesta
special formats and ground sides on request



SAN MAMANTE

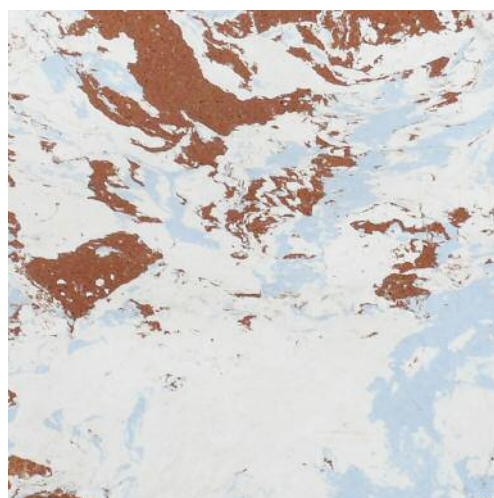

ORIENTE



OCCIDENTE

NOTE:

cotto fatto a mano - colori e caratteristiche estetiche sono da considerarsi indicativi, misure nominali
handmade terracotta - colors and aesthetic characteristics are to be considered indicative, nominal measurements

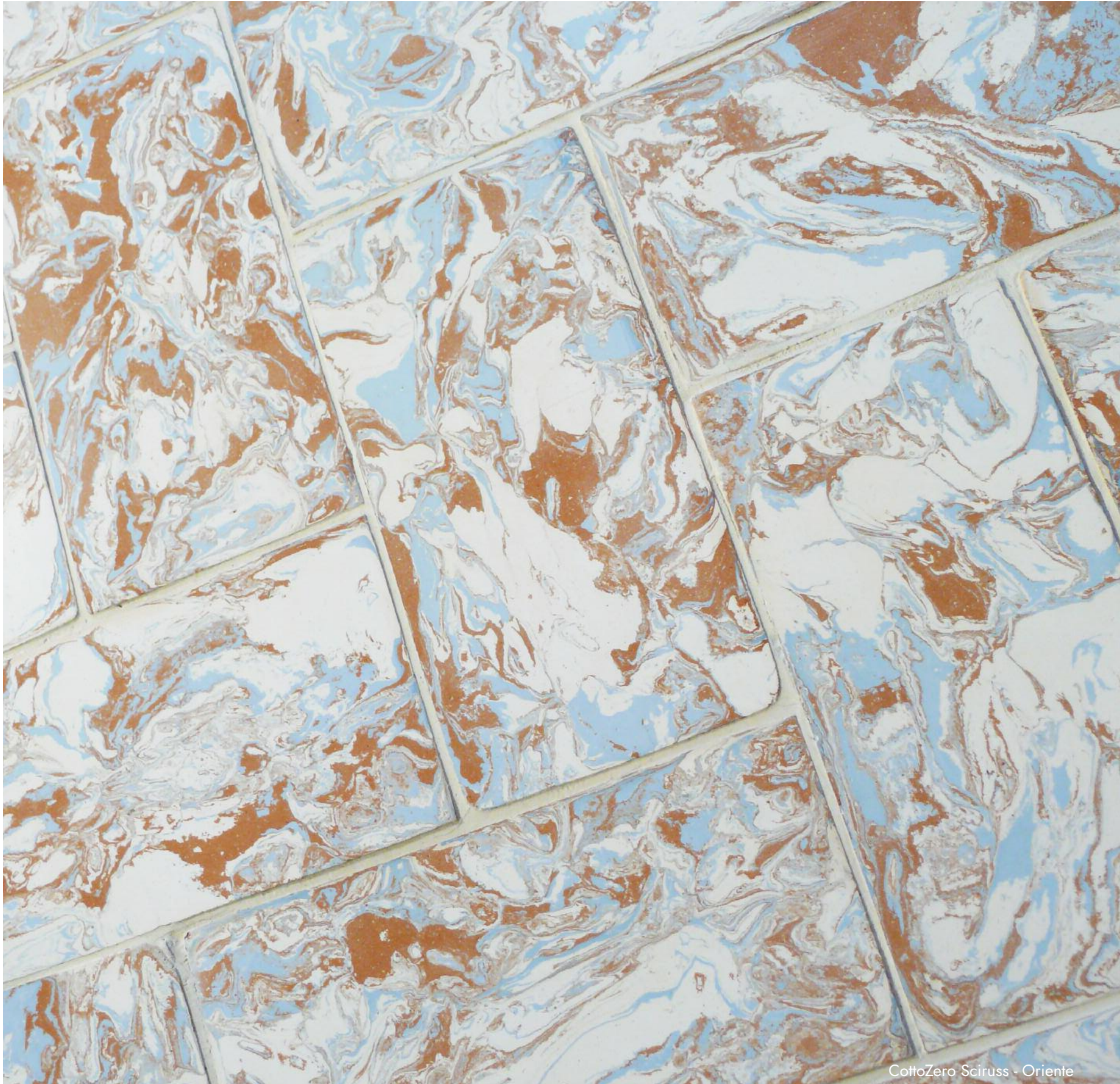

**COTTO
ZERO**

S

CIRUSS

SIZES COLORS:

QUADRATO / SQUARE

10x10x2	cm - 3" ¹⁵ / ₁₆ x 3" ¹⁵ / ₁₆ x ²⁵ / ₃₂ "
20x20x2	cm - 7" ⁷ / ₈ x 7" ⁷ / ₈ x ²⁵ / ₃₂ "
25x25x2	cm - 9" ²⁷ / ₃₂ x 9" ²⁷ / ₃₂ x ²⁵ / ₃₂ "
30x30x2	cm - 11" ¹³ / ₁₆ x 11" ¹³ / ₁₆ x ²⁵ / ₃₂ "
40x40x2,5	cm - 15" ³ / ₄ x 15" ³ / ₄ x ⁶³ / ₆₄ "

RETTANGOLO / RECTANGLE

10x40x2	cm - 3" ¹⁵ / ₁₆ 15" ³ / ₄ x ²⁵ / ₃₂ "
12x48x2	cm - 4" ²³ / ₃₂ x 18" ⁵ / ₆₄ x ²⁵ / ₃₂ "
15x30x2	cm - 5" ²⁹ / ₃₂ x 11" ¹³ / ₁₆ x ²⁵ / ₃₂ "
20x40x2	cm - 7" ⁷ / ₈ x 15" ³ / ₄ x ²⁵ / ₃₂ "
30x60x2	cm - 11" ¹³ / ₁₆ x 23" ⁵ / ₈ x ²⁵ / ₃₂ "

ROMBO / RHOMBUS

16,5x29x2	cm - 6" ¹ / ₂ x 11" ²⁷ / ₆₄ x ²⁵ / ₃₂ "
-----------	---

ESAGONO / EXAGON

Lato 11 cm, sp. 2 cm	- Side 4" ²³ / ₆₄ , THK ²⁵ / ₃₂ "
Lato 16 cm, sp. 2 cm	- Side 6" ¹⁹ / ₆₄ , THK ²⁵ / ₃₂ "

FINITURE / FINISHING

levigato a mano / smoothed by hand

PEZZI SPECIALI / SPECIAL PIECES

pezzi per scale e battiscopa vedi pag. 108
pieces for stairs and baseboard on page 108

CUSTOM MADE

formati speciali e lati rettificati a richiesta
special formats and ground sides on request

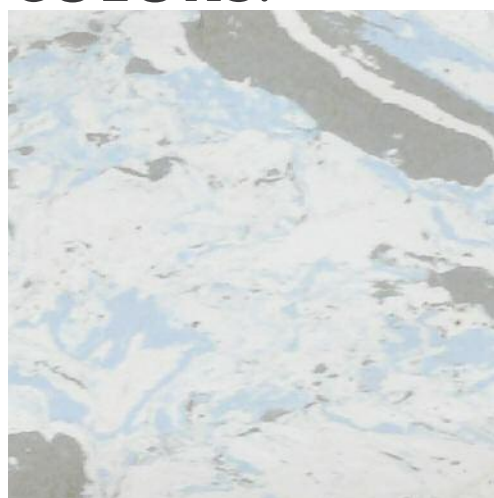

GHIACCIAIO

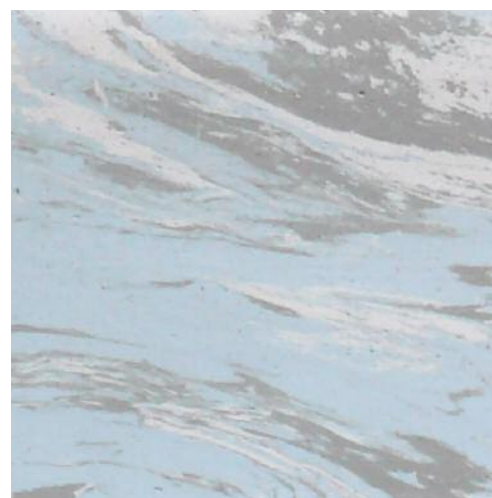

BLU NOTTE



VULCANO

NOTE:

cotto fatto a mano - colori e caratteristiche estetiche sono da considerarsi indicativi, misure nominali
handmade terracotta - colors and aesthetic characteristics are to be considered indicative, nominal measurements



**COTTO
ZERO**

S

CIRUSS & SOLID COLORS

TINTE UNITE IN ABBINAMENTO / SOLID COLORS IN COMBINATION

La particolare lavorazione "a pane" dei cotti variegati ne caratterizza la superficie, per questo, per le eventuali tinte unite da usare in accostamento viene utilizzata la stessa tecnica.

The particular "bread" processing of the Sciruss terracotta tiles characterizes the surface, for this reason the same technique is used for any solid colors to be used in combination.



SAN MAMANTE



ORIENTE



OCCIDENTE



VULCANO



VENTILATO ROSSO

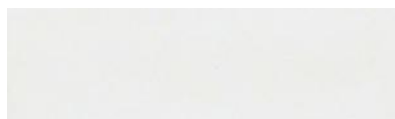

VENTILATO BIANCO

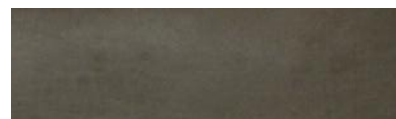

VENTILATO PECE



VENTILATO PERLA*



VENTILATOT ROSSO ANTICO



VENTILATO ROSSO

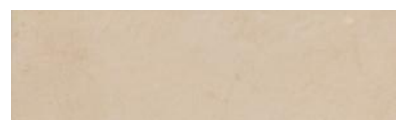

VENTILATO CIPRIA



VENTILATO TORTORA

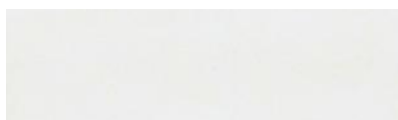

VENTILATO BIANCO



VENTILATO AZZURRO



VENTILATO PERLA*



VENTILATO FUMO



VENTILATO TORTORA

* prodotto speciale realizzato su richiesta / special product made on request



GHIACCIAIO



BLUNOTTE



VENTILATO BIANCO



VENTILATO AZZURRO



VENTILATO AZZURRO

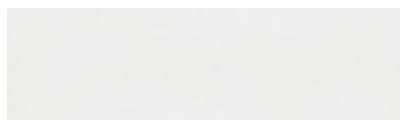

VENTILATO BIANCO

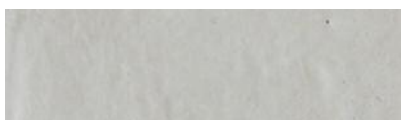

VENTILATO POLVERE*



VENTILATO TORTORA

COTTO ZERO DESIGN

Linee pulite e semplici vengono enfatizzate dalla matericità e dalla naturalezza del cotto e trasformano CottoZero nel vero protagonista di elementi d'arredo e inedite tarsie.

Clean and simple lines are emphasized by the materiality and naturalness of the terracotta and transform CottoZero into the true protagonist of furnishing elements and original inlays.

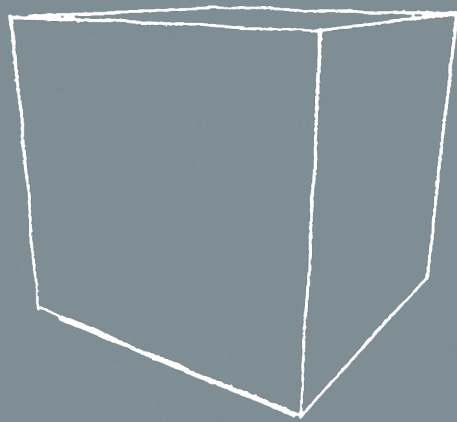
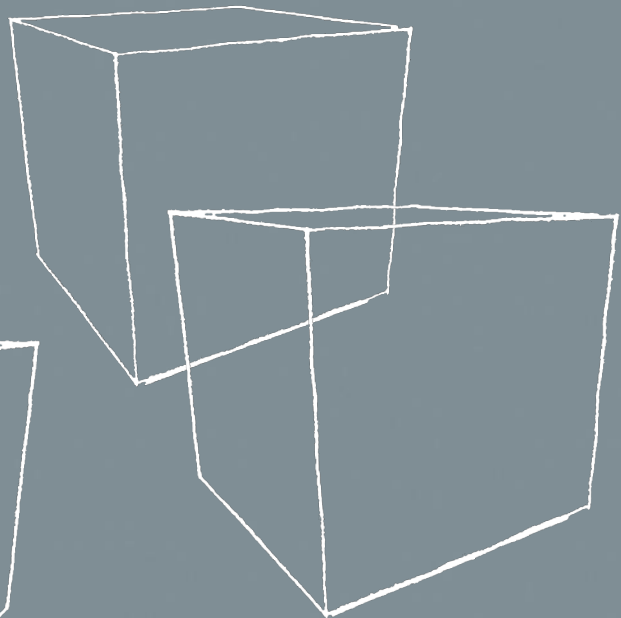
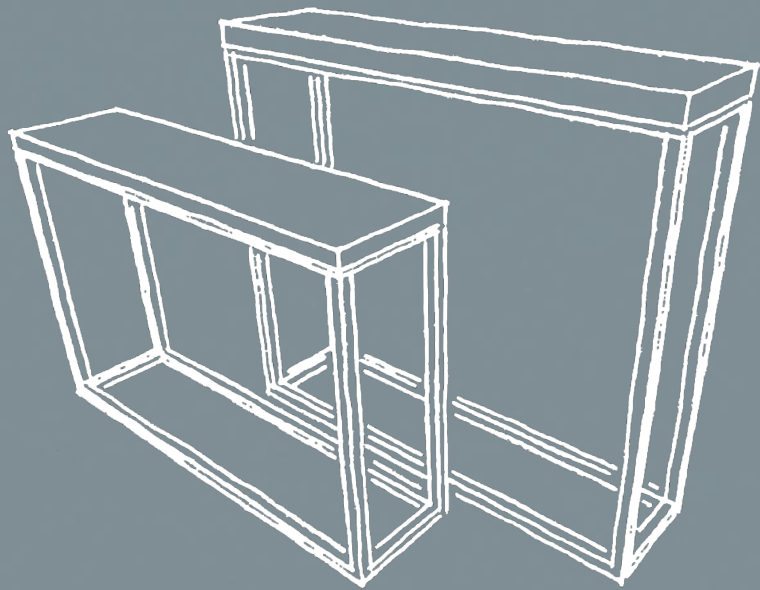
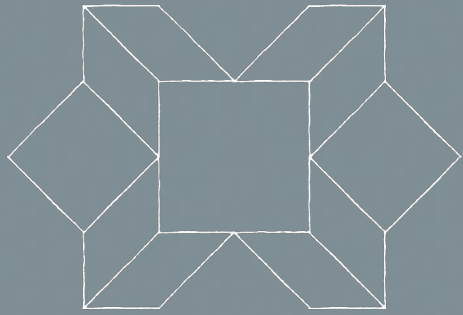

**COTTO
ZERO**



COSMATI

DIAMANTE

SIZES:
30X30x2cm - 11¹³/₁₆ x 11¹³/₁₆ x 2⁵/₃₂"

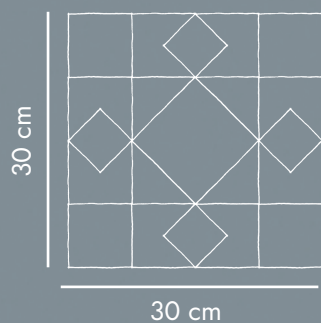

Modulo per pavimentazione realizzabile
in tutti i colori della gamma CottoZero.

*Flooring module workable in all colors
of the CottoZero range.*

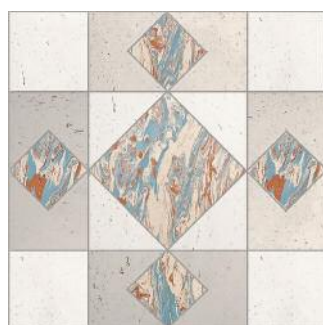

VARIAZIONE ORIENTE



VARIAZIONE TORTORA

NOTE

* formati ottenuti da taglio; lati dritti
* formats obtained by cutting; sides straight

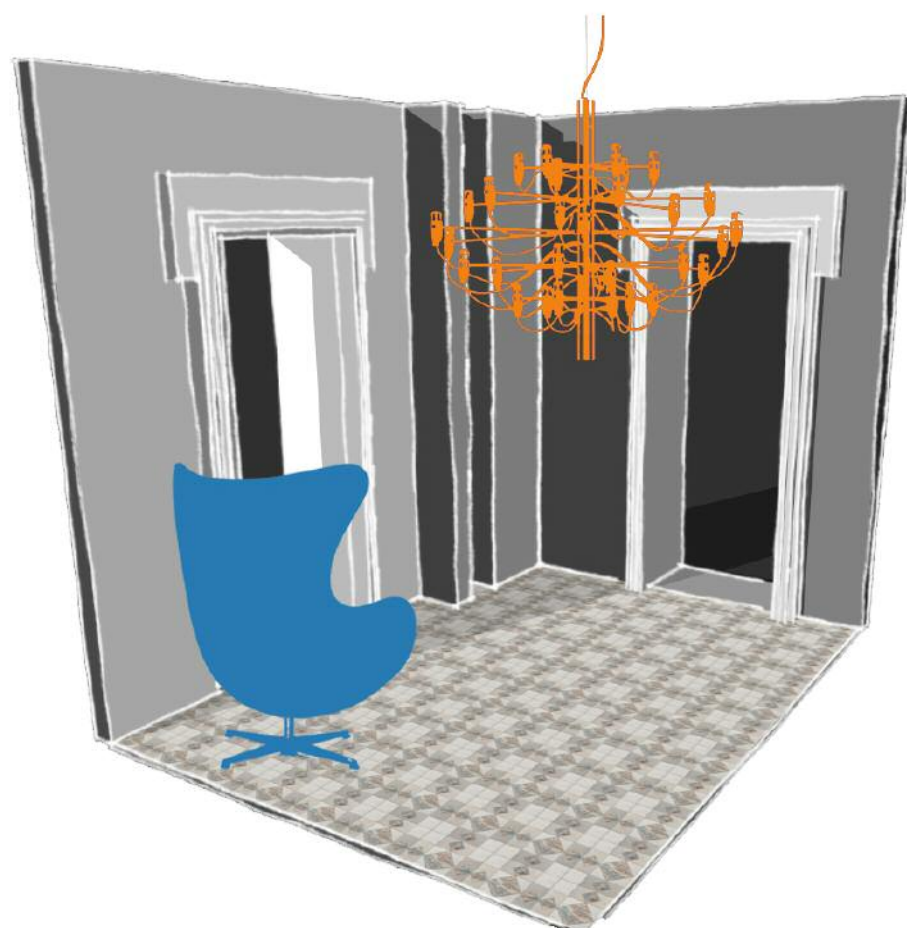

STELLA

SIZES:
30x45x2cm - 11" ¹³/₁₆ x 17" ²³/₃₂ x 25" ³²/₃₂"

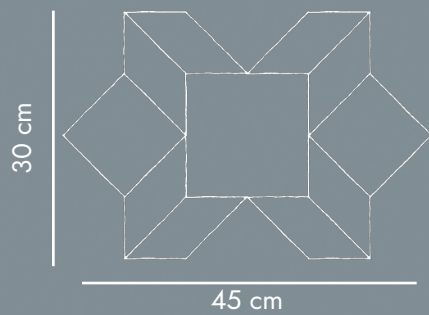

Modulo per pavimentazione realizzabile
in tutti i colori della gamma CottoZero.

*Flooring module workable in all colors
of the CottoZero range.*

NOTE:

* formati ottenuti da taglio; lati dritti
* formats obtained by cutting; sides stright



VARIAZIONE DI AZZURRO



VARIAZIONE DI ROSSO



COTTO ZERO



COSMATI

TARTARUGA

SIZES:
61x52x2cm - 24" ¹/₆₄ x 20" ¹⁵/₃₂ x 2" ²⁵/₃₂"

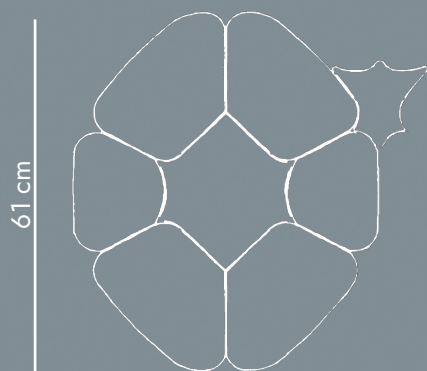

52 cm

DESIGN:
Zani Zeta J@n Design

Modulo per pavimentazione realizzabile
in tutti i colori della gamma CottoZero.

*Flooring module workable in all colors
of the CottoZero range.*

NOTE:

* formati ottenuti da taglio; lati dritti
* formats obtained by cutting; sides straight



VARIAZIONE DI GRIGIO



VARIAZIONE DI ROSSO

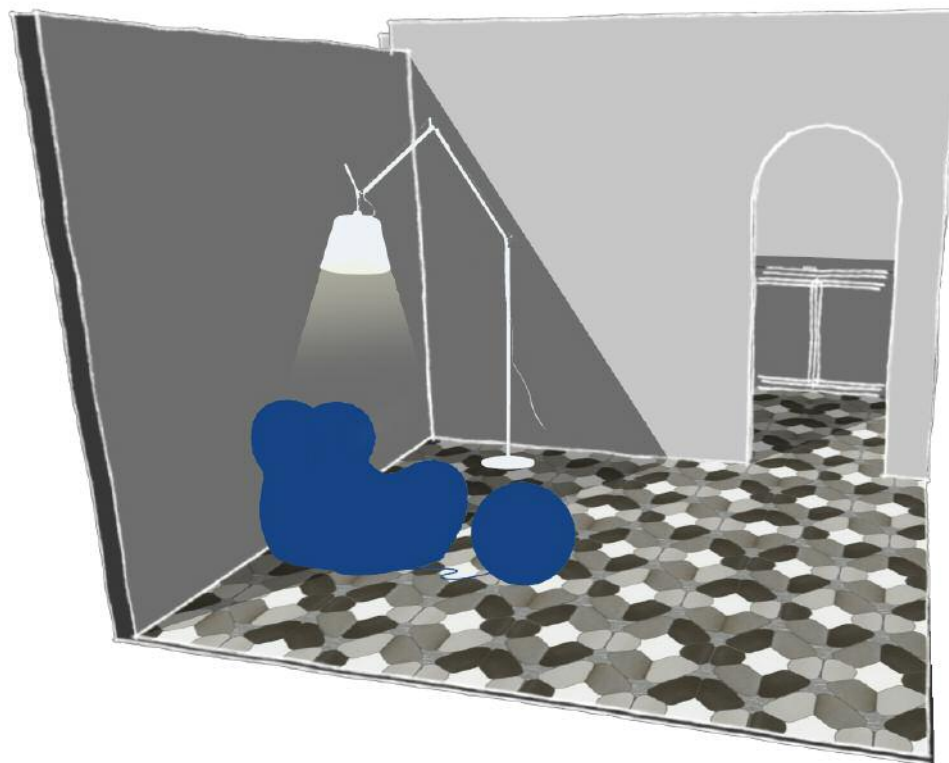

INTRECCIO

SIZES:
60x60x2cm - 17" ²³/₃₂" x 17" ²³/₃₂" x 25" ²⁵/₃₂"

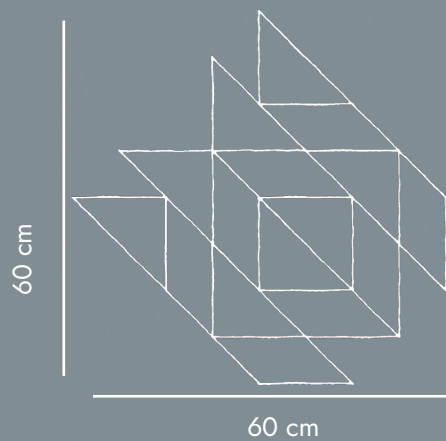

Modulo per pavimentazione realizzabile
in tutti i colori della gamma CottoZero.

*Flooring module workable in all colors
of the CottoZero range.*

NOTE:

* formati ottenuti da taglio; lati dritti
* formats obtained by cutting; sides straight



VARIAZIONE DI ROSSO



VARIAZIONE DI GRIGIO

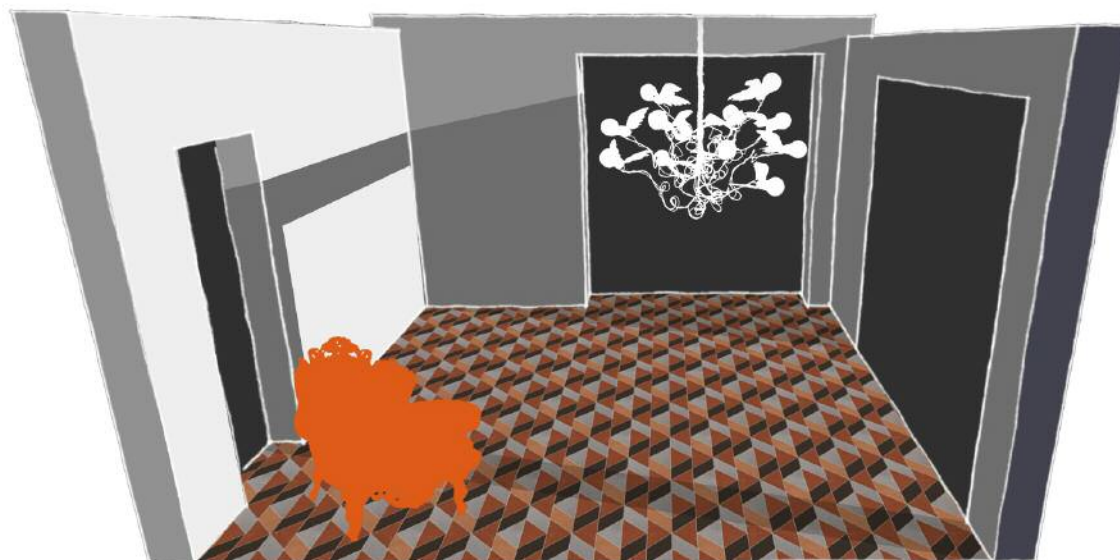

**COTTO
ZERO**

**C
UBE**

pouf/coffee table

SIZES:

39x39cm - h 41cm

15" ²³/₆₄ x 15" ²³/₆₄ - h 16" ⁹/₆₄

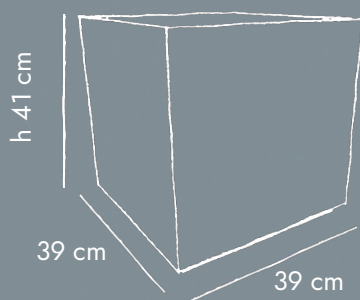

DETAILS

Struttura in legno multistrato
rivestita in CottoZero.
Scuretto in smalto nero.
Realizzabile in tutti i colori CottoZero

*Multilayer wood structure
covered in CottoZero.
foot enamelled in black.
Can be made in all CottoZero colours*

NOTE:

* formati ottenuti da taglio; lati con microbisello
* formats obtained by cutting; sides with micro-bevel



**COTTO
ZERO**
N

OT CUBE

consolle

SIZES:

20x80cm - h 60/ h 80 cm

7 ⁷/₈ x 31 ¹/₂ - h 23 ⁵/₈ - h 31 ¹/₂

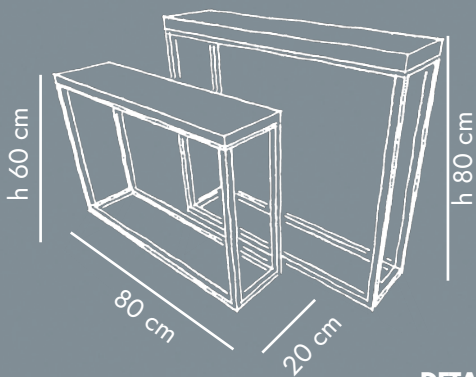

DETAILS

Struttura in ferro nero.
Top in CottoZero.
Realizzabile in tutti i colori CottoZero.

*Black iron structure.
Top in CottoZero.
Can be made in all CottoZero colours.*

NOTE:

* formati ottenuti da taglio; lati con microbisello
* formats obtained by cutting; sides with microbevel



COTTO
ZERO

LINE

mensola/shelf

SIZES:

15x30x3cm - 5" ²⁹/₃₂ X 11" ¹³/₁₆ X 1" ³/₁₆

15X60X3,5 cm - 5" ²⁹/₃₂ X 23" ⁵/₈ X 1" ³/₈

altre misure a richiesta

other sizes on request

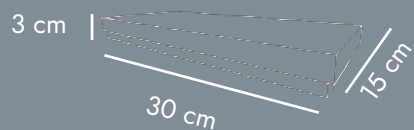
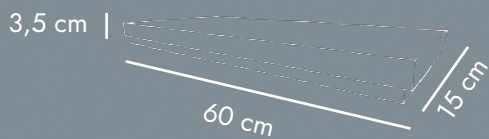

DETAILS

Struttura in ferro nero.

Top in CottoZero.

Realizzabile in tutti i colori CottoZero.

Black iron structure.

Top in CottoZero.

Can be made in all CottoZero colours.

NOTE:

* formati ottenuti da taglio; lati con microbisello

* formats obtained by cutting; sides with micro-bevel



COTTO ZERO

CITTA'

game/sculpture

SIZES:

20x40x2cm - 7" ⁷/₈ x 15" ³/₄ x ²⁵/₃₂"

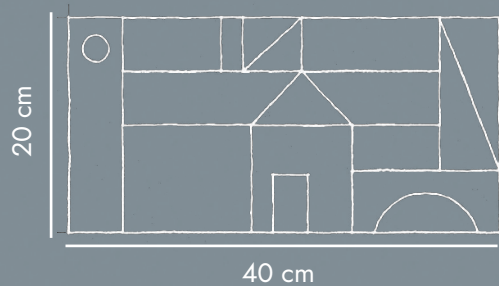

DETAILS

Gioco/scultura in CottoZero.
I colori sono forniti in modo casuale.

*Game/sculpture in CottoZero.
The colors are provided randomly.*

NOTE:

* formati ottenuti da taglio; lati dritti
* formats obtained by cutting; straight sides

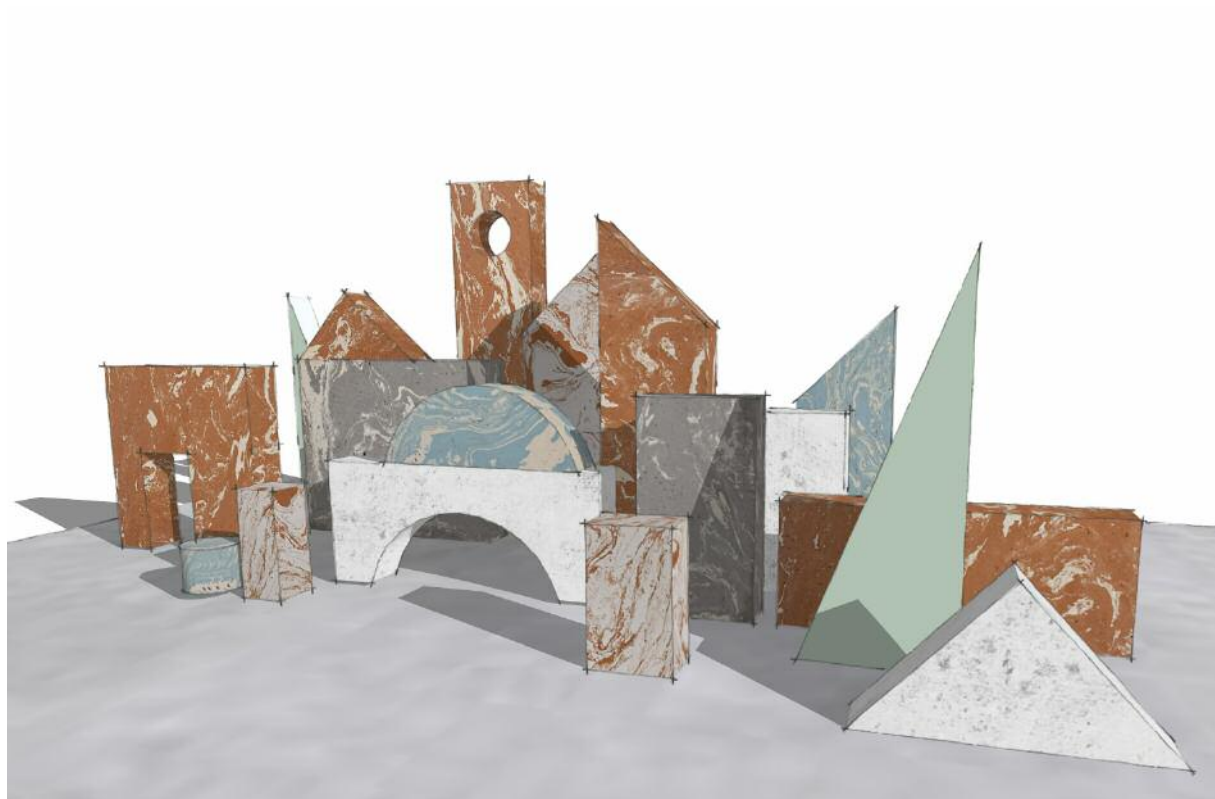



STAYCATION
GUIDE

KINFOLK TRAVEL

Homecamp

A white facade, five floors and an open door.

GRAANMARKT 13

Aviel Yervoordt
Interieurprenten



DETTAGLI TECNICI
DETAILS



ARATTERISTICHE DELLE COLLEZIONI

COLLECTIONS CHARACTERISTICS

LE COLLEZIONI THE COLLECTIONS

Tutte le nostre collezioni sono realizzate a mano in Italia nei nostri stabilimenti di Vaprio D'Agogna.

I nostri cotti vengono stampati a mano, per questo le misure indicate nel presente catalogo sono da considerarsi nominali.

Le colorazioni dei nostri cotti dipendono direttamente dalla colorazione delle argille. Lievi differenze di tono tra i campioni e le forniture, o all'interno delle forniture stesse, sono da considerarsi carattere distintivo e di pregio dei prodotti naturali.

Pur eseguendo i manufatti con la massima cura, i bordi anche se rettilinei sono comunque eseguiti a mano, per questo è necessario in fase di posa considerare una fuga congrua. I nostri cotti vengono forniti non trattati.

All our collections are handmade in Italy in our factories in Vaprio D'Agogna.

Our tiles are hand-moulded, which is why the measurements indicated in this catalogue are to be considered nominal.

The colours of our cottos depend directly on the colouring of the clays.

Slight differences in tone between the samples and the deliveries, or within the deliveries themselves, are to be considered distinctive and valuable characteristics of natural products.

Although we execute the products with the utmost care, the edges, even if straight, are still executed by hand, which is why it is necessary to consider a suitable joint when laying.

Our terracotta products are supplied untreated.

COTTOZERO ITALIA

La collezione CottoZero Italia è fornita con finitura naturale, senza alcun intervento aggiuntivo dopo l'estrazione dal forno.

Il cotto emergerà in tutta la sua bellezza dopo le operazioni di posa e pulizia.

The CottoZero Italia collection is supplied with a natural finish, without any additional intervention after removal from the kiln. The cotto will emerge in all its beauty after laying and cleaning.

COTTO ZERO ITALIA ANTICA

La collezione Italia Antica possiede una particolare superficie anticata che presenta delle cavità sia sui bordi che sulla superficie.

Queste cavità, in fase di stuccatura andranno ad accogliere lo stucco evidenziando il carattere antico della pavimentazione.

The Italia Antica collection has a special antiqued surface with cavities both on the edges and on the surface.

These cavities, when grouted, will accommodate the stucco, highlighting the antique character of the flooring.

COTTOZERO COTTO STORICO PIEMONTESE

La collezione Cotto Storico Piemontese è frutto di una ricerca sui cotti antichi di produzione locale.

Presenta una colorazione particolare arricchita da piccole inclusioni di dimensioni variabili dai toni che vanno dall'avorio al rosso bruno.

Durante le operazioni di levigatura è possibile che alcune inclusioni generino dei piccoli fori sulla superficie che saranno colmati durante la stuccatura del materiale.

The Cotto Storico Piemontese collection is the result of research into locally produced antique terracotta. It presents a particular colouring enriched by small inclusions of varying sizes in tones ranging from ivory to reddish-brown. During polishing operations, it is possible that some inclusions generate small holes on the surface that will be filled during the grouting of the material.

COTTOZERO ARGILLE NOBILI

La collezione Argille Nobili è una collezione caratterizzata da una particolare sfumatura superficiale.

La sfumatura di colore bruno rossiccio è realizzata grazie ad un'attenta carteggiatura manuale, eseguita pezzo per pezzo, che preserva di tanto in tanto gli accumuli di sabbia sulla superficie del manufatto.

Questa collezione oltre ad avere grande matericità risulta essere una delle collezioni più stonalizzate.

The Argille Nobili collection is characterised by a particular surface nuance. The reddish-brown shade is achieved through careful manual sanding, performed piece by piece, which occasionally preserves the accumulations of sand on the surface of the artefact. This collection not only has great materiality but is also one of the most shaded collections.

COTTOZERO TERRE PURE

La collezione Terre Pure è una collezione ispirata alla matericità dell'argilla. La sua finitura spazzolata evidenzia in modo morbido e naturale i movimenti superficiali della terracotta.

The Terre Pure collection is a collection inspired by the materiality of clay. Its brushed finish highlights the surface movements of terracotta in a soft and natural way.

COTTO ZERO PIETRAME

La collezione Pietrame è caratterizzata dalla presenza di piccole inclusioni dalle dimensioni e sfumature diverse. Questi frammenti miscelati alle argille di base creano una texture grafica casuale dal grande appeal. Le diverse colorazioni dal bianco al rosso bruno creano una vibrazione cromatica molto armonica in combinazione al colore di fondo rendendo ogni manufatto un oggetto da scoprire e da apprezzare sia nella sua singolarità che nella visione complessiva della pavimentazione. Durante le operazioni di levigatura è possibile che alcune inclusioni generino dei piccoli fori sulla superficie, questi saranno colmati durante la stuccatura del materiale.

The Pietrame collection is characterised by the presence of small inclusions of different sizes and shades. These fragments mixed with the base clays create random graphic texture with great appeal. The different colours from white to red-brown create a very harmonious chromatic vibration in combination with the background colour, making each artefact an object to be discovered and appreciated both in its singularity and in the overall vision of the floor. During sanding operations it is possible that some inclusions will generate small holes in the surface, these will be filled during the grouting of the material.

COTTOZERO VENTILATO

La collezione Ventilato propone una lettura estremamente tecnica e contemporanea del materiale.

Il particolare metodo di realizzazione applicato permette di ottenere su ogni singolo pezzo una superficie dall'aspetto unito ed omogeneo.

The Ventilato collection offers an extremely technical and contemporary interpretation of the material.

The particular manufacturing method applied allows us to obtain a surface with a united and homogeneous appearance on each individual piece.

COTTOZERO VARIEGATO SCIRUSS

Le collezioni Variegato e Sciruss sono realizzate mescolando impasti di argille di diversi colori.

La variegatura e le sfumature che si ottengono sono in parte frutto dell'abilità delle nostre maestranze e in parte determinate dal caso.

Questa sinergia fa sì che ogni manufatto presenti variegature e sfumature uniche ed irripetibili.

The Variegato and Sciruss collections are made by mixing clay mixtures of different colors.

The variegation and nuances obtained are partly the result of the skill of our workers and partly determined by chance.

This synergy means that each artefact presents unique and unrepeatable variegations and nuances.

**COTTO
ZERO**

S

CALE/BATTISCOPIA TAIRS/BASEBOARD

DETAILS

Pezzi speciali per la realizzazione di scale interne, esterne, top e bordi piscina. Misure personalizzate a richiesta.

Special pieces for the construction of internal and external stairs, tops and pool edges. Customized sizes on request.

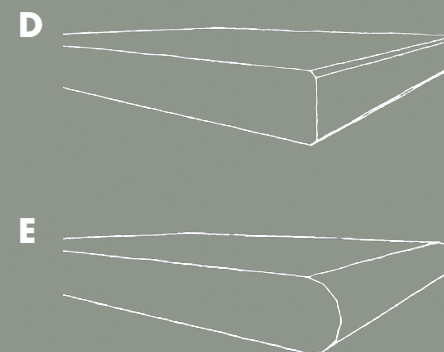
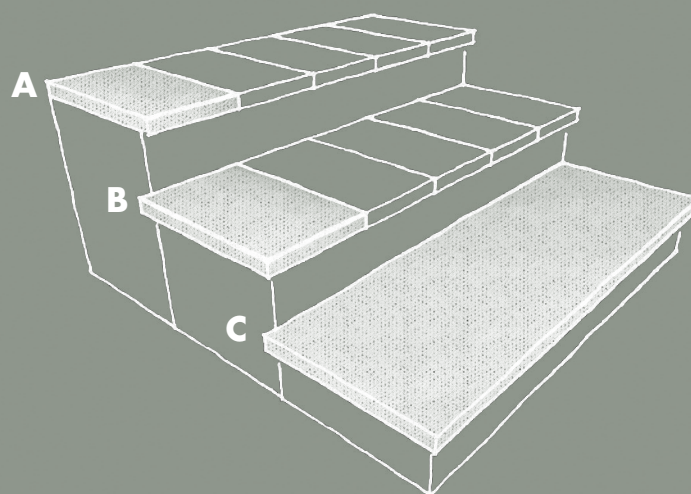

SCALE/STAIRS

A - GRADINO / STEP

20x35x3 cm - 7" ⁷/₈ x 13" ²²/₃₂ x 1" ³/₁₆

1 costa da 20 cm lavorata / 1 side of 20 cm - 7" ⁷/₈ finished

B - GRADINO ANGOLARE / CORNER STEP

22,5x35x3 cm - 8" ⁵⁵/₆₄ x 13" ²²/₃₂ x 1" ³/₁₆

2 coste adiacenti lavorate / 2 adjacent sides worked

C - GRADONE / BIG STEP

100x35x3 cm - 39" ³/₈ x 13" ²²/₃₂ x 1" ³/₁₆

Disponibile con 1, 2 o 3 coste lavorate / Available with 1, 2 or 3 sides worked

Misure inferiori a richiesta / Smaller sizes on request

LAVORAZIONE COSTA/SIDE PROCESSING

D - DOPPIO BISELLO / DOUBLE BEVEL

E - TORO / BULLNOSE

NOTE:

Materiale fatto a mano, misure nominali
Gradone - non è disponibile per le collezioni
CottoZero Variegato e CottoZero Sciruss

*Handmade material, nominal sizes
Big step - is not available for the CottoZero
Variegato and CottoZero Sciruss collections*

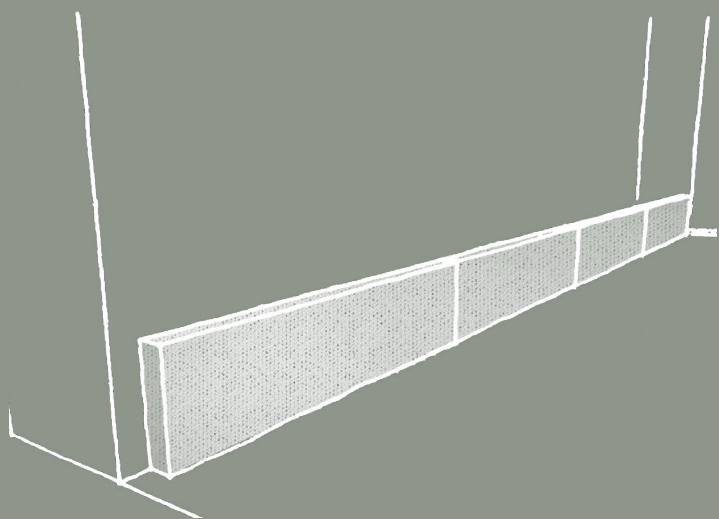

BATTISCOPA/BASEBOARD

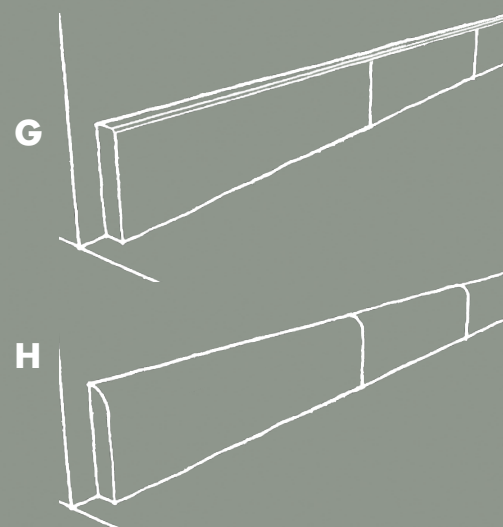

LAVORAZIONE COSTA/SIDE PROCESSING

G - BISELLO/BEVEL

8x33x2 cm - 3'' ⁵/₃₂ X 12'' ⁶³/₆₄ X ²⁵/₃₂''

H - BECCO DI CIVETTA

8x34x2 cm - 3'' ⁵/₃₂ X 13'' ²⁵/₆₄ X ²⁵/₃₂''

**COTTO
ZERO**

SIZES

DETAILS

A RICHIESTA:

Formati su misura da stampo.
Sottomisure e formati speciali
ottenuti da taglio* di formati più grandi

ON REQUEST

*Custom printed formats.
Special shapes and sub-dimensions
obtained by cutting* of larger formats*

schema di riferimento /reference scheme

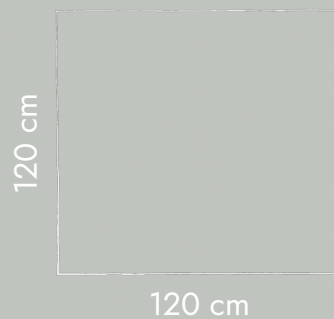

NOTE:

Materiale fatto a mano, misure nominali
Handmade material, nominal sizes

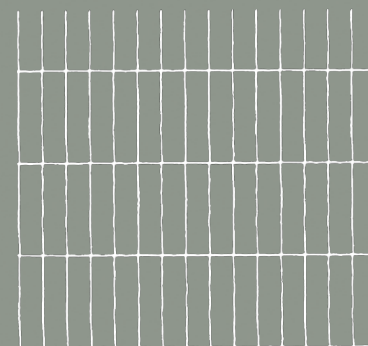

$3'' \frac{5}{32} \times 12'' \frac{63}{64} \times \frac{25}{32}''$ **



ROMBO 16,5x29x2cm
rhombus $6'' \frac{1}{2} \times 11'' \frac{27}{64} \times \frac{25}{32}''$

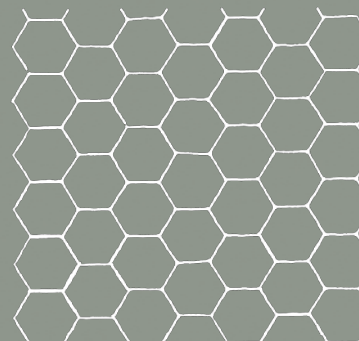

ESAGONO lato 11cm x 2cm
hexagon side $4'' \frac{21}{64} \times \frac{25}{32}''$

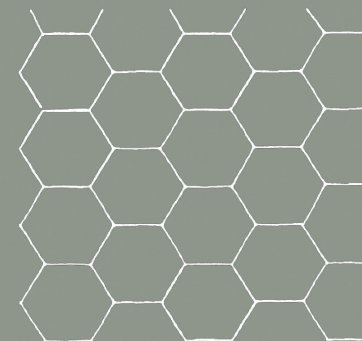

ESAGONO lato 16cm x 2cm
hexagon side $6'' \frac{19}{64} \times \frac{25}{32}''$

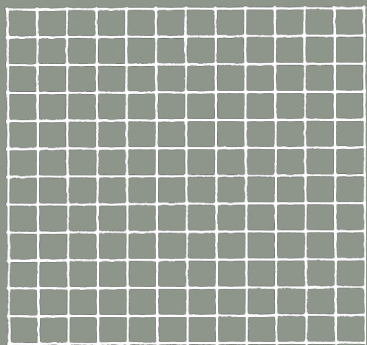

10x10x2cm*
 $3'' \frac{15}{16} \times 3'' \frac{15}{16} \times 25 \frac{25}{32}''$ *

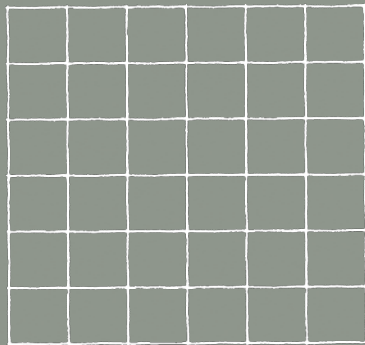

20x20x2cm
 $7'' \frac{7}{8} \times 7'' \frac{7}{8} \times 25 \frac{25}{32}''$

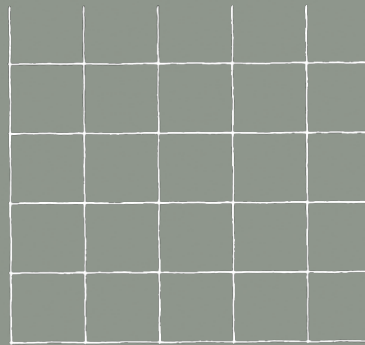

25x25x2cm
 $9'' \frac{27}{32} \times 9'' \frac{27}{32} \times 25 \frac{25}{32}''$

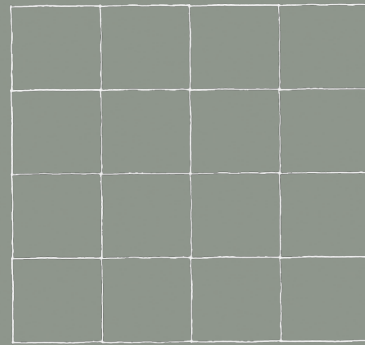

30x30x2cm
 $11'' \frac{13}{16} \times 11'' \frac{13}{16} \times 25 \frac{25}{32}''$

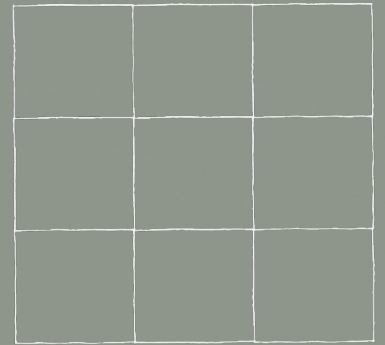

40x40x2,5cm
 $15'' \frac{3}{4} \times 15'' \frac{3}{4} \times 63 \frac{63}{64}''$

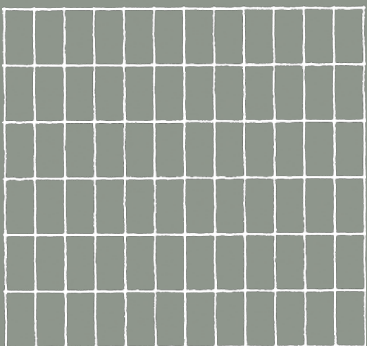

10x20x2cm*
 $3'' \frac{15}{16} \times 7'' \frac{7}{8} \times 25 \frac{25}{32}''$ *

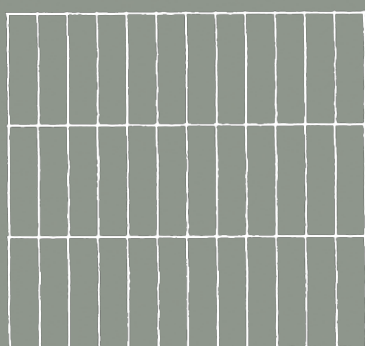

10x40x2cm
 $3'' \frac{15}{16} \times 15'' \frac{3}{4} \times 25 \frac{25}{32}''$

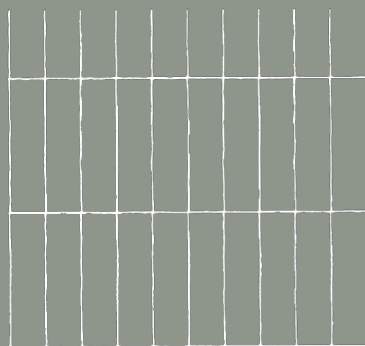

12x48x2cm
 $4'' \frac{23}{32} \times 18'' \frac{57}{64} \times 25 \frac{25}{32}''$

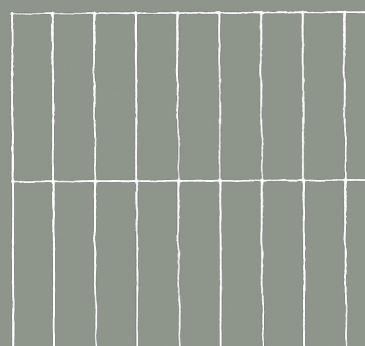

14x60x2,5cm**
 $5'' \frac{33}{64} \times 23'' \frac{5}{8} \times 63 \frac{63}{64}''$

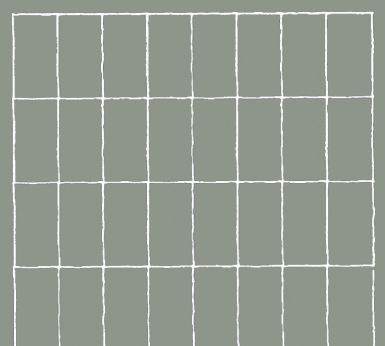

15x30x2cm
 $5'' \frac{29}{32} \times 11'' \frac{13}{16} \times 25 \frac{25}{32}''$

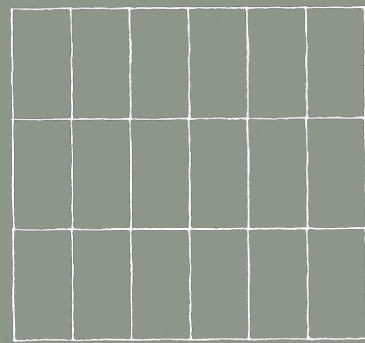

20x40x2cm
 $7'' \frac{7}{8} \times 15'' \frac{3}{4} \times 25 \frac{25}{32}''$

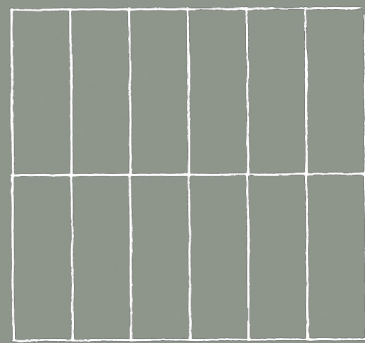

20x60x3cm**
 $7'' \frac{7}{8} \times 23'' \frac{5}{8} \times 1 \frac{3}{16}''$ **

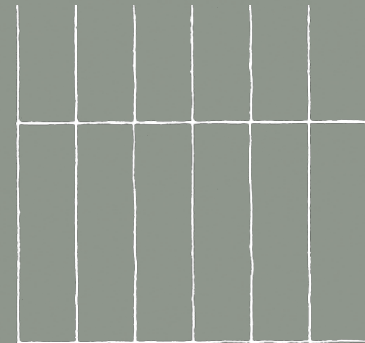

20x80x3cm**
 $7'' \frac{7}{8} \times 31'' \frac{1}{2} \times 1 \frac{3}{16}''$ **

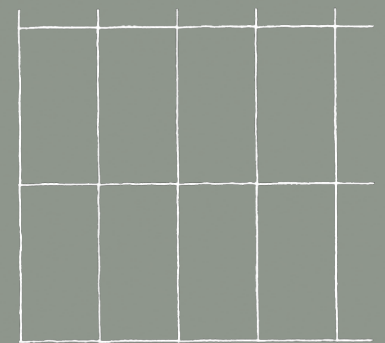

30x60x2cm
 $11'' \frac{13}{16} \times 23'' \frac{5}{8} \times 25 \frac{25}{32}''$

*formato a richiesta ottenuto da taglio / *size on request obtained by cutting

**formato non disponibile per le collezioni CottoZero Ventilato, Variegato e Sciruss/ **size not available for collections CottoZero Ventilato, Variegato e Sciruss

COTTO ZERO

LAYER

DETAILS

NOTE:

Materiali fatti a mano, misure nominali.
Per pose multicolore e/o multiformato, il tipo di
posa scelto deve essere comunicato
al momento della richiesta.

*Handmade materials, nominal size.
For multicolor and/or multiformat poses,
the type of pose chosen must be communicated
at the time of the request.*

A RICHIESTA / ON REQUEST

Formati su misura da stampo,
sottomisure e formati speciali
ottenuti da taglio di formati più grandi

*Custom printed formats
special shapes and sub-dimensions
obtained by cutting of larger formats*

schema di riferimento / reference scheme

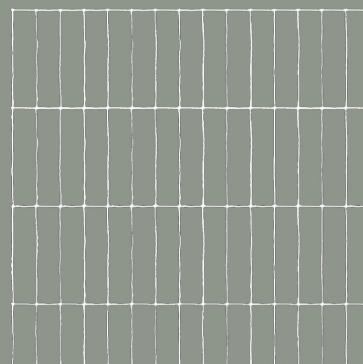
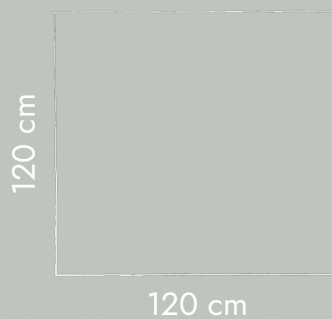

IN LINEA
8x33cm

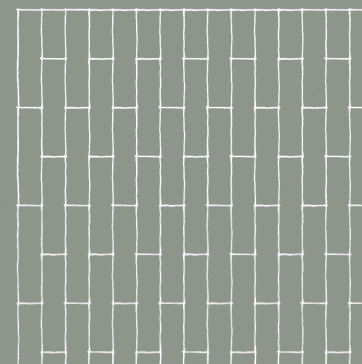

SFALSATA 1/2
8X33cm

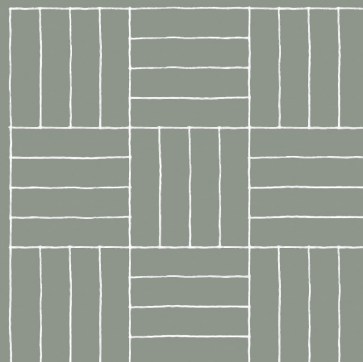

INTRECCIO
10x40cm

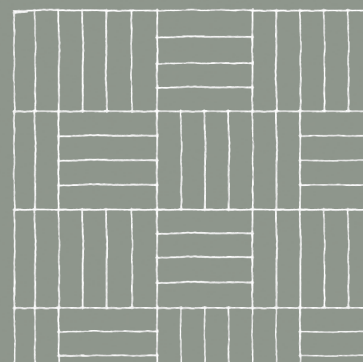

INTRECCIO CON BINDELLO
10x40cm

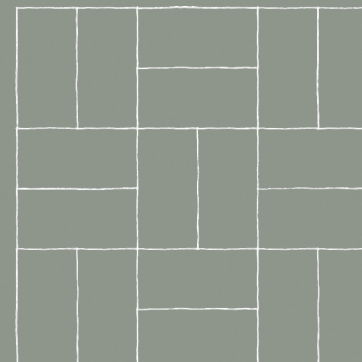

INTRECCIO
20x40xcm

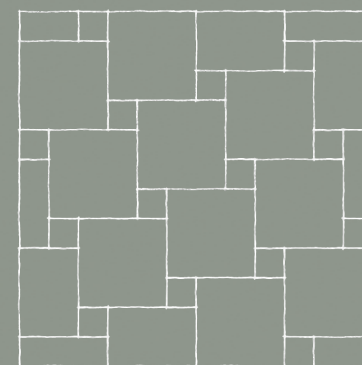

CON TOZZETTO
30x30cm/10x10xcm

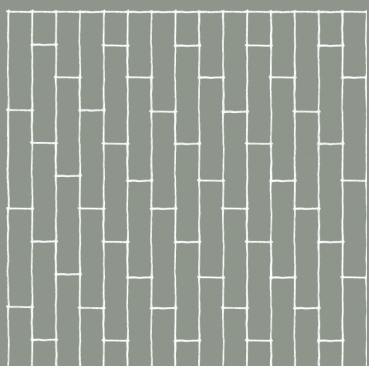

SFALSATA 1/3
8X33cm

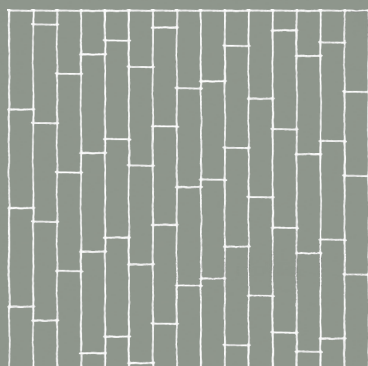

A CORRERE
8X33cm

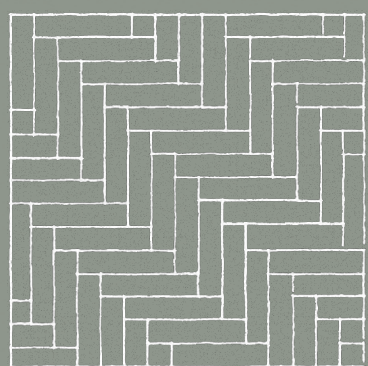

SPINA ITALIANA
8X33cm

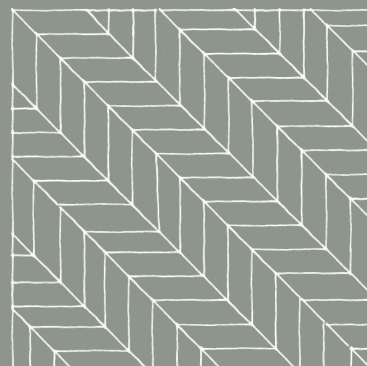

SPINA FRANCESE
8X33cm

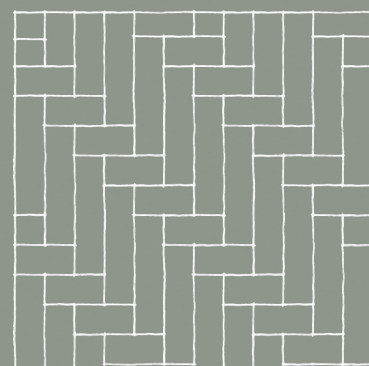

SPINA ASIMMETRICA
10x20cm/10x40cm

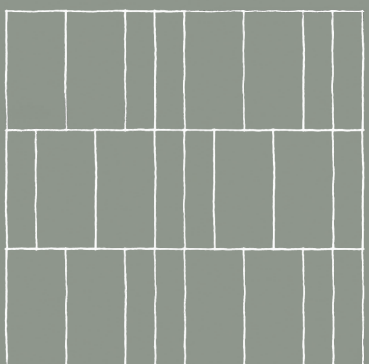

MULTIFORMATO
10x40cm/20x40cm

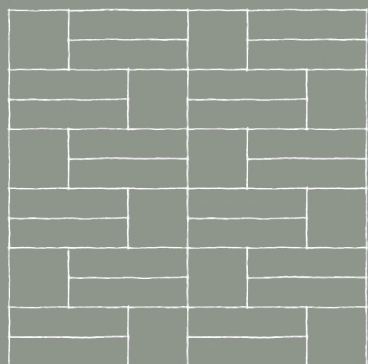

MULTIFORMATO
10x40cm/20x20cm

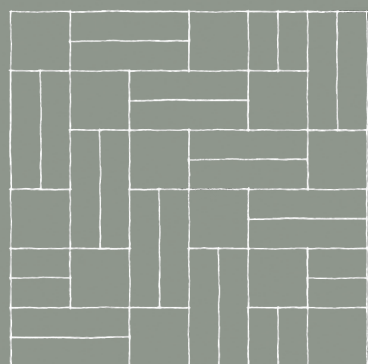

MULTIFORMATO
10x40cm/20x20cm

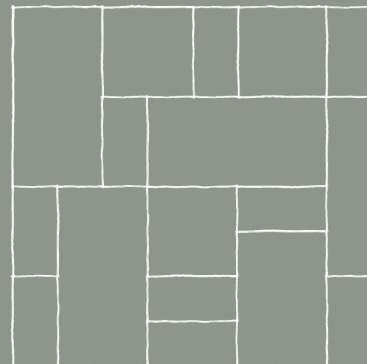

MULTIFORMATO
15/30/60x30cm

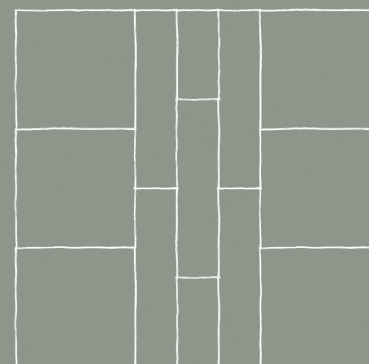

MULTIFORMATO
40x40cm/14x60cm

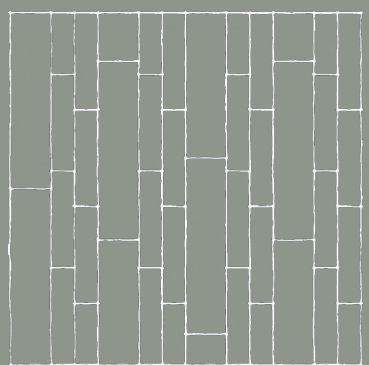

MULTIFORMATO A CORRERE
8X33x cm/15x60xcm

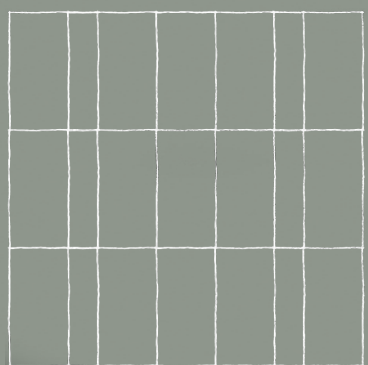

MULTIFORMATO IN LINEA
20X40cm /10X40cm

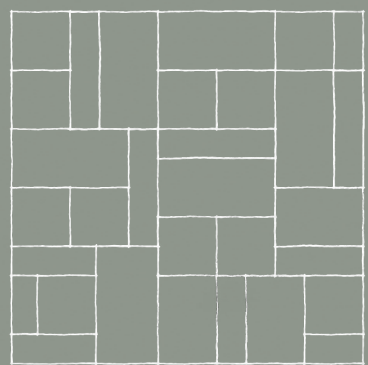

MULTIFORMATO
20X20 cm /10X40 /20x40 cm

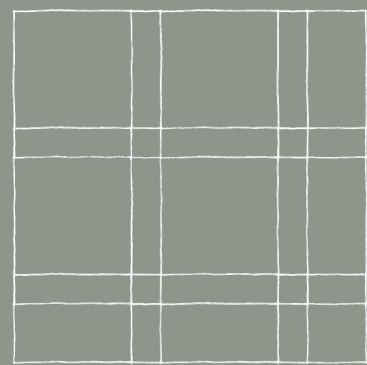

CORNICE
40x40 cm/10x40 cm/10x10cm

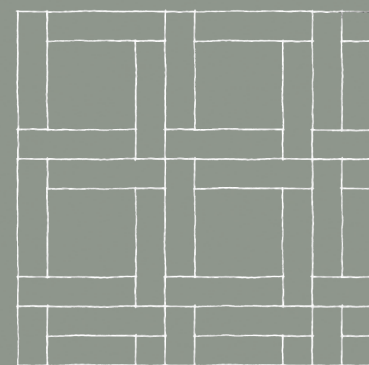

MULTIFORMATO
20x20 cm 10x40 cm

**COTTO
ZERO**



**COLORI
COLORS**

**COTTO STORICO
PIEMONTESE**



BELLA RUSIN

ITALIA



ROSATO



ROSSO

ITALIA ANTICA



ROSATO



ROSSO

ARGILLE NOBILI



STRESA



VERBANIA



ORTA



ARONA



BAVENO



CANNOBIO

TERRE PURE



BIANCO



CIPRIA



ROSSO ANTICO



ROSSO

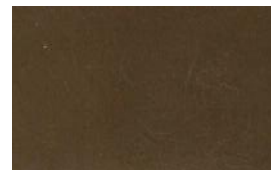

NOCE



NUVOLA



POLVERE



TORTORA



FUMO



PECE



AZZURRO



VERDE

PIETRAME



BIANCO



PERLA



ROSSO ANTICO



ROSSO



NOCE



PECE



AZZURRO

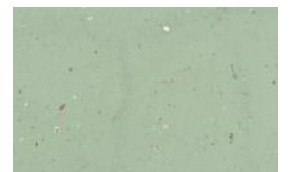

BELLA RUSIN

VENTILATO

BIANCO



NUVOLA



CIPRIA



TORTORA

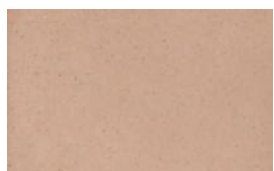

ROSATO



FUMO

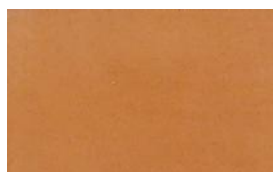

ROSSO ANTICO



PECE



ROSSO

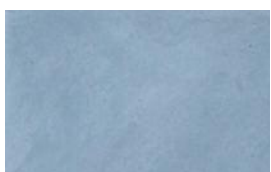

BLU

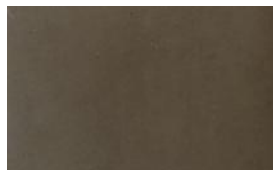

NOCE



AZZURRO



VERDE

VARIEGATO

BIANCO VAR. CIPRIA



BIANCO VAR. ROSSO



ROSSO VAR. BIANCO



ROSSO VAR. GIALLO



ROSSO VAR. TORTORA



ROSSO VAR. AZZURRO



ROSSO VAR. VERDE



BIANCO VAR. TORTORA



BIANCO VAR. VERDE



BIANCO VAR. AZZURRO



BIANCO VAR. PECE



AZZURRO VAR. BIANCO



TORTORA VAR. BIANCO



FUMO VAR. PERLA



PECE VAR. AZZURRO



PECE VAR. BIANCO



PECE VAR. VERDE



NOCE VAR. BIANCO



NOCE VAR. AZZURRO

SCIRUSS

GHIACCIAIO

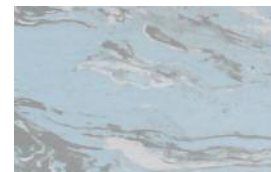

BLU NOTTE



ORIENTE



SAN MAMANTE



VULCANO



OCCIDENTE



DANILO RAMAZZOTTI
ITALIANHOUSEFLOOR

www.daniloramazzotti.com

CottoZero is a brand of: Gruppo Ceramico Cantoia s.r.l. - Via Novara,41 28010 Vaprio d'Agogna (NO) Italy
+39 0321 966948 - info@daniloramazzotti.com